



DE Aufbauanleitung Gerätehaus „AvantGarde®“ Gr. M, L, XL

- Ⓞ GB Assembly manual for garden shed "AvantGarde®" size M, L, XL
- Ⓞ FR Notice de montage pour l'abri de jardin "AvantGarde®" taille M, L, XL
- Ⓞ NL Opbouwbeschrijving berging "AvantGarde®" grootte M, L, XL
- Ⓞ ES Instrucciones de montaje de la caseta modelo "AvantGarde®" tamaño M, L, XL
- Ⓞ IT Istruzioni di montaggio Casetta portattrezzi "AvantGarde®" misura M, L, XL
- Ⓞ DK Monteringsvejledning for redskabsskuret "AvantGarde®" størrelse M, L, XL



 Poiščite váš prevod na ...

 Najděte svůj překlad ...

 Hitta din översättning ...

 Finn din oversettelse ...

 Találja meg fordítását ...



Wichtige Punkte für den Aufbau!

Vorliegende Aufbauanleitung zeigt den Zusammenbau von „AvantGarde®“ Größe „L“; sie gilt sinngemäß auch für die Größe „M“ und „XL“. Für einige Montageschritte benötigen Sie 1 bis 2 Helfer.

- GB *Important details regarding assembly! This assembly manual shows the erection of the garden shed model “AvantGarde®” size “L”; it is also valid for size “M” and “XL” For several assembly steps additional assistance of 1 or 2 people will be required.*
- FR *Points importants lors du montage! Cette notice de montage décrit l’assemblage de l’abri “AvantGarde®” taille « L »; celle-ci est aussi valable pour la taille « M » et « XL ». Pour certaines étapes, demandez l’aide d’une ou deux personnes.*
- NL *Deze montage instructies hebben betrekking op de opbouw van de AvantGarde®, grootte L. De instructies zijn ook van toepassing op de grootte M en XL. Voor enkele montage stappen heeft u 1 of 2 extra mensen nodig.*
- ES *Notas importantes para el montaje: Estas instrucciones muestran el montaje de la caseta “AvantGarde” en tamaño L. También son válidas para el tamaño M y XL. Es recomendable realizar el montaje entre dos o tres personas.*
- IT *Indicazioni importanti per il montaggio! Le seguenti istruzioni di montaggio fanno riferimento all’assemblaggio di “AvantGarde®” misura “L”; per analogia sono valide anche per la misura “M” e “XL”. Per alcune fasi di assemblaggio vi serviranno 1 - 2 aiutanti.*
- DK *Vigtige punkter ved samling! Samlemanualen viser opsætningen af havekur modellen “AvantGarde” str. “L”; gælder også for størrelse “M” og “XL”. Ved flere punkter af opsætningen er yderligere hjælp påkrævet af 1 eller 2 personer.*



Um Kratzer zu vermeiden, verwenden Sie bitte geeignete Unterlagen!

- GB *Please use a suitable underlay to avoid scratches!*
- FR *Pour éviter les rayures, utilisez les supports appropriés!*
- NL *Om krassen te voorkomen raden wij u aan er iets onder te leggen!*
- ES *Por favor, coloque en el suelo una base protectora adecuada para evitar posibles arañazos.*
- IT *Utilizzare una base adatta per evitare graffi!*
- DK *Benyt venligst et passende underlag for at undgå skrammer!*



Schraubverbindungen grundsätzlich erst am Ende der Montage festziehen!

- GB *Nuts not to be tightened before the end of assembly!*
- FR *Ne serrer les écrous à fond qu’à la fin du montage!*
- NL *Schroeven pas aan het einde van de montage vastdraaien!*
- ES *En principio, no apriete fijamente las tuercas hasta que no haya terminado de montar la caseta.*
- IT *I dadi devono essere serrati a fondo soltanto alla fine del montaggio!*
- DK *Møtrikkerne må ikke strammes før slutningen af opsætningen!*

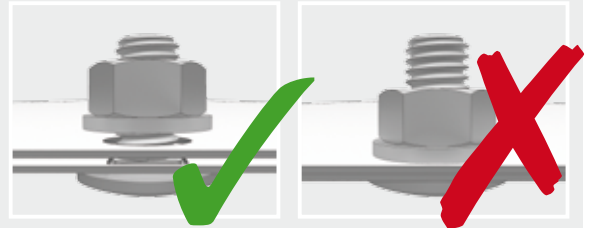

Wasserwaagen - Symbol:

Betreffendes Einbauteil mit der Wasserwaage ausrichten.

- GB *Symbol of spirit level: Align the respective parts by using the spirit level.*
- FR *Symbole niveau à bulle: Lorsque ce symbole apparaît, vous devez ajuster l’élément à l’aide d’un niveau à bulle.*
- NL *Waterpas - symbool: Bij montagestappen waar dit symbool bijstaat is het noodzakelijk het betreffende onderdeel waterpas in te bouwen.*
- ES *Símbolo del nivelador: Indica que se debe ajustar y centrar la pieza con la ayuda de un nivelador.*
- IT *Simbolo di livella a bolla d’aria: Allineare il componente in questione con l’ausilio di una livella a bolla d’aria.*
- DK *Symbol for vaterpas: Juster de respektive dele ved hjælp af vaterpas.*

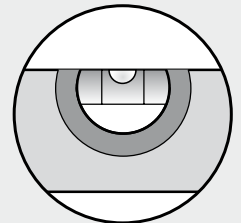

Maßstabsgetreue Abbildung der zu verwendenden Schrauben:

- GB *Scale drawing 1:1 of the screws in use*
- FR *Reproduction selon l’échelle 1:1.*
- NL *Afbeelding : schaal 1:1 (ware grootte)*
- ES *Reproducción a escala 1:1 de los tornillos que se utilizan para el montaje.*
- IT *Immagine in scala delle viti da utilizzare!*
- DK *Skala tegning af skruer er 1:1*

M 1:1

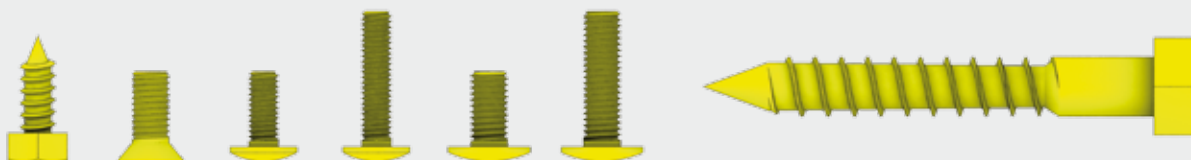

4,8 x 13

M5 x 12

M4 x 10

M4 x 18

M5 x 10

M5 x 18

8 x 60



Größenabhängiger Montageschritt!

- (GB) Size-Dependent assembly step!
- (FR) Dépendant de la taille assemblage étape!
- (NL) Size-Dependent montagestap!
- (ES) Paso de montaje de tamaño Dependiente!
- (IT) Taglia-Dependent fase di montaggio!
- (DK) Størrelses-afhængig montage skridt

Größenabhängiger Montageschritt



Nur für Größe XL

Only for size XL - Uniquement pour taille XL



Optionales Zubehör - Symbol:

Arbeitsschritte, die blau eingrahmt sind, zeigen den Einbau eines optionalen Zubehörteiles.

- (GB) Symbol of optional accessories: Blue framed assembly steps show the installation of optional accessories.
- (FR) Accessoires en option-Symbole: La trame entourée en bleu indique une étape avec accessoires en option. A réaliser uniquement si vous avez commandé cet accessoire.
- (NL) Extra Toebehoor: Montagestappen met een blauwe rand betreffen de inbouw van extra toebehoor.
- (ES) Accesorio opcional - símbolo: Los pasos de montaje que se encuentran enmarcados en azul muestran el montaje de una pieza de un accesorio opcional.
- (IT) Simbolo per accessori opzionali: Le fasi del montaggio incorniciate in colore azzurro mostrano l'installazione di un accessorio opzionale.
- (DK) Symbol for ekstra udstyr: Blåt indrammet samletrin viser installationen af ekstraudstyr

optionales Zubehör - Accessoires



Bodenrahmen

Floor Frame - Cadre de sol



Maße für das Fundament

- (GB) Foundation dimensions
- (FR) Dimensions pour la fondation
- (NL) Maat voor het fundament
- (ES) Medidas de los cimientos
- (IT) Dimensioni del basamento
- (DK)

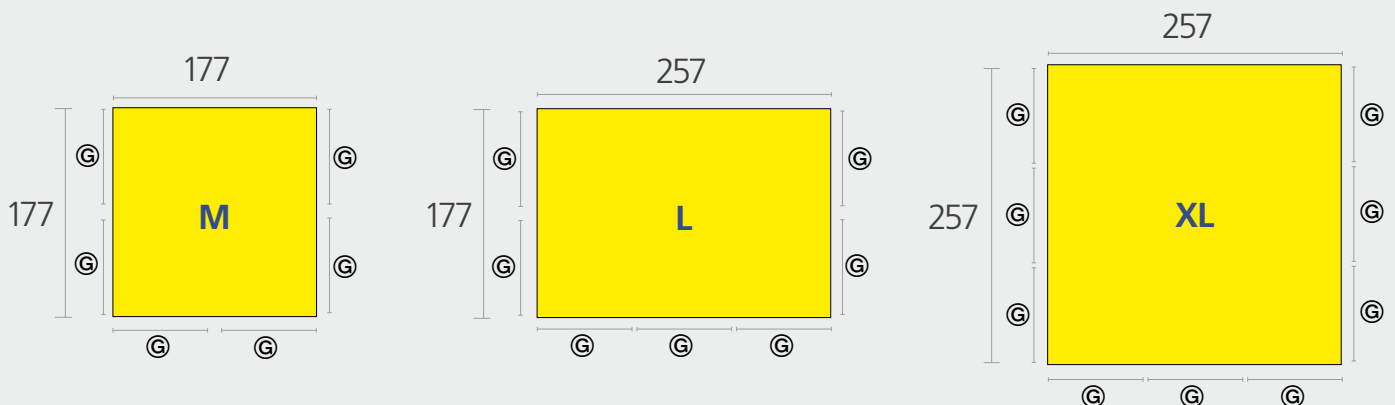

Einbaumöglichkeiten der Türen anstelle von Wandelementen!

- (GB) The door can be installed instead of a side wall element!
- (FR) La porte peut être installée sur le côté à la place d'une paroi latérale !
- (NL) Inbouwmogelijkheden van de deuren i.p.v. de wandelementen
- (ES) Es posible colocar las puertas en lugar de los paneles laterales.
- (IT) Considerare la possibilità di montare una porta standard al posto di una parete laterale!
- (DK) Døren kan monteres i stedet for et sidevæg element!

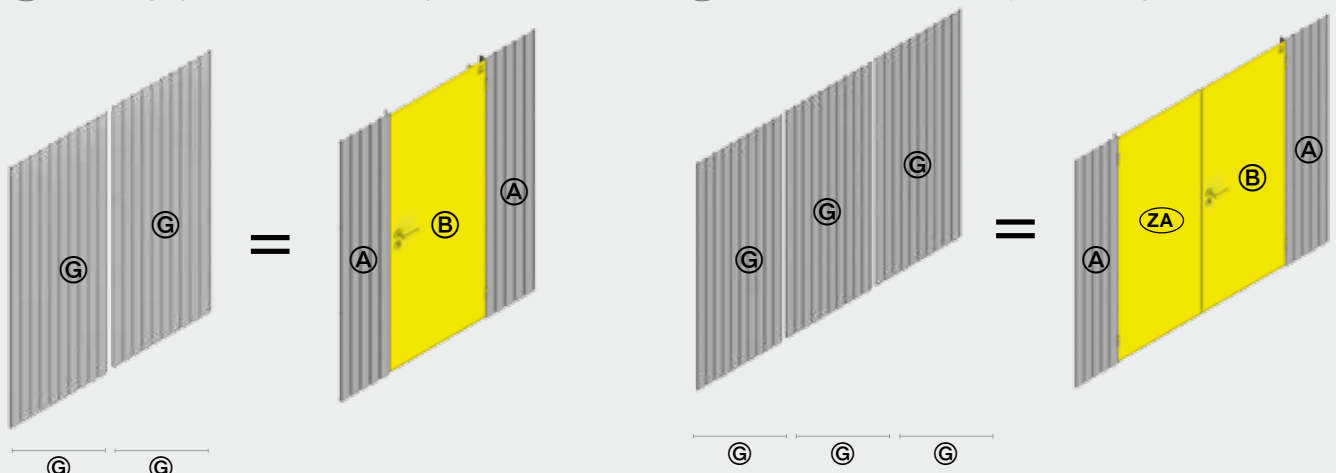



Nicht bei Wind aufbauen!

- (GB) Do not assemble the shed on a windy day!
- (FR) Ne pas assembler quand il y a du vent !
- (NL) Niet bij wind opbouwen!

- (ES) No monte la caseta si hace mucho viento.
- (IT) Non montare la casetta in giornate di vento!
- (DK) Saml ikke skuret på en blæsende dag!



Verwenden Sie bei der Montage Arbeitshandschuhe!

- (GB) Wear working gloves!
- (FR) Portez des gants de travail
- (NL) Handschoenen gebruiken!

- (ES) Utilice unos guantes de trabajo.
- (IT) Utilizzare guanti da lavoro
- (DK) Brug arbejdshandsker!



Vorschläge für das Fundament

Bitte achten Sie bei der Fundamentgestaltung darauf, dass Niederschlagswasser nicht seitlich unter den Bodenprofilen in das Gerätehaus eindringen kann! (siehe Varianten 1, 2, 3). Aufsteigende Bodenfeuchtigkeit und Kondensation vermeiden Sie mittels einer starken Kunststoffolie unter dem Fundament.

(GB) Proposals for a secure foundation

When making the foundation arrangements please take necessary precaution to ensure that water cannot leak in under the floor profiles (see option 1, 2, 3). Rising ground moisture and condensation can be avoided by using a strong plastic sheet underneath the paving slabs or underneath the concrete foundation.

(FR) Conseils pour les fondations

Lors de la réalisation de la fondation, veillez à ce que l'eau de pluie ne puisse pas pénétrer dans l'abri ou par les côtés sous les profils de sol (voir variantes 1, 2, 3). Vous pouvez éviter l'humidité du sol et la condensation en mettant un film plastique épais sous les plaques de béton.

(NL) Voorstellen voor fundament

Let er bij het maken van de fundering op dat regenwater niet onder het bodemprofiel kan doorlopen (zie voorbeeld 1, 2, 3). Een vochtige bodem en condensatie kunt u vermijden door het aanbrengen van een sterke kunststoffolie onder de tegels of het betonfundament.

(ES) Medidas y recomendaciones para los cimientos:

Al colocar los cimientos, asegúrese de que el agua de lluvia no puede penetrar en la caseta por los laterales debajo del perfil del suelo (véase variante 1, 2 y 3). Evite la humedad y la condensación en el suelo colocando una lámina de plástico bajo las losas o los cimientos de hormigón.

(IT) Proposte per il basamento:

Il basamento deve essere progettato in modo da evitare infiltrazioni di acqua piovana all'interno della casetta (vedere proposta 1-2-3). Un telo di plastica spesso posto in corrispondenza dell'area di pavimento evita infiltrazioni di umidità dal terreno e la formazione di condensa.

(DK) Forslag til sikkert fundament:

Ved etablering af fundament skal du tage de nødvendige forholdsregler for at sikre, at vand ikke kan sive ind under gulvprofilerne (se mulighed 1, 2, 3). Stigende fugt og kondens i jorden kan undgås ved at bruge plastik under flisebelægningen eller under betonfundamentet.



Weitere Details betreffend Fundament finden Sie auch unter www.biohort.com/Fundament

Further details about foundations you will find on www.biohort.com/foundation

Pour des détails supplémentaires, veuillez consulter www.biohort.com/fondations

Verdere details over het fundament vindt u ook op www.biohort.com/fundament

Encuentre información detallada sobre los cimientos en: www.biohort.com > servicios > cimientos

Per ulteriori dettagli si prega di consultare www.biohort.com/it/servizi/suggerimenti-per-le-fondamenta/

Ydertigere informationer om fundamentet finder du på www.biohort.com/foundation

ACHTUNG ATTENTION
ATTENTION | ATTENTIE |
ATENCIÓN | ATTENZIONE |
OBS.



Die Verankerung ist wichtig, denken Sie an Sturmböen!

Do not forget to anchor the shed against gale force wind!

L'ancrage est important, pensez aux rafales de vent!

Verankering niet vergeten!

El anclaje es muy importante. Piense por ejemplo en rachas fuertes de viento.

L'ancoraggio della casetta è importante - pericolo in caso di raffiche di vento!

Glem ikke at forankre skuret mod vinde af stormstyrke!

Variante, Proposal, Variant 1



Variante, Proposal, Variant 2

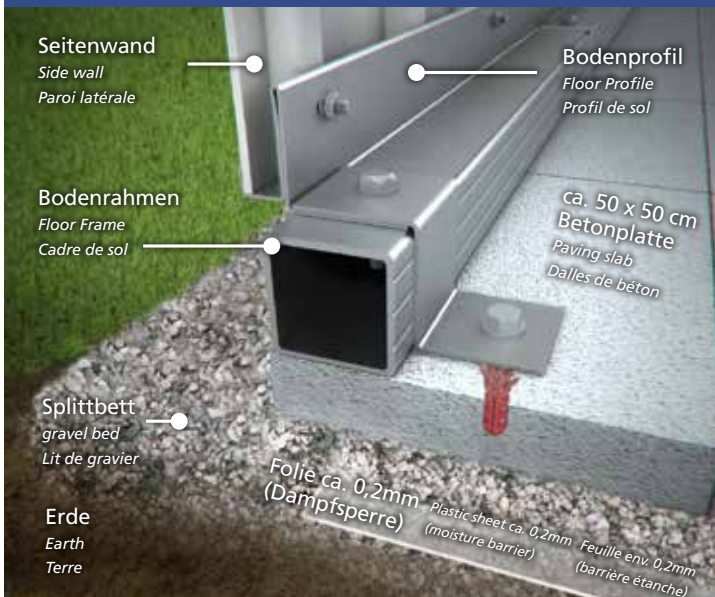

Variante, Proposal, Variant 3

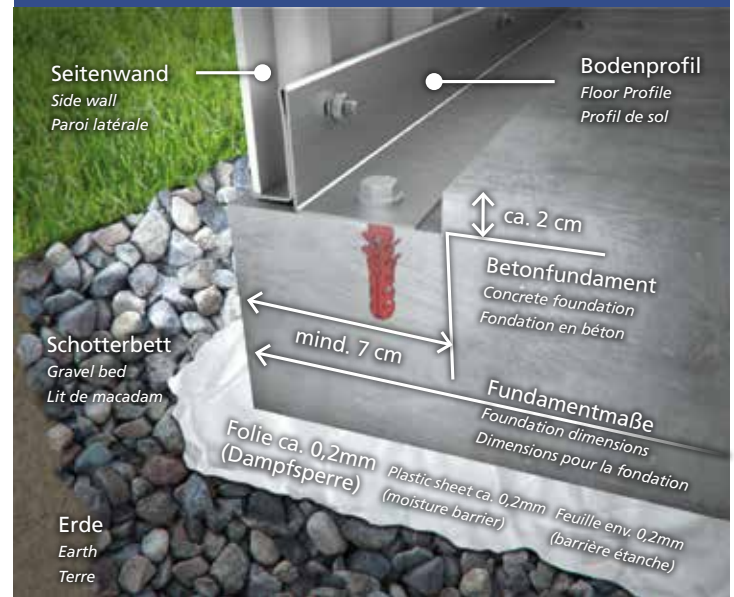

Pflege und Wartung

- Keine aggressiven Chemikalien wie z.B. Chlor oder Streusalz lagern!
- Sonnenmilch und andere Cremes mit Wasser und Seife entfernen.
- Keine scheuernden Reinigungsmittel verwenden!
- Laub vom Dach regelmäßig entfernen!
- Dachrinnenauslauf kontrollieren!
- Tiefe Kratzer sofort mit beiliegendem Lack ausbessern!
- Ölen Sie das Schloss jährlich!

(EN) Care and maintenance

- Do not store aggressive substances i.e. chlorine or road salt!
- Remove suntan lotion or any other creams with water and rinse aid!
- Do not use abrasive cleaning agents!
- Keep the roof free of leaves!
- Check the gutter!
- Touch-up scratches immediately with the paint provided.
- Lubricate the lock once a year!

(FR) Entretien et maintenance

- Ne pas stocker de produits chimiques (chlore, sel, etc...!)
- Nettoyez uniquement avec de l'eau les crèmes solaires et autres crèmes (pas de nettoyant chimique).
- Ne pas utiliser de produits nettoyant abrasifs!
- Débarrassez vous régulièrement des feuilles mortes sur le toit!
- Contrôlez l'évacuation de la gouttière!
- Corrigez immédiatement les rayures avec la laque jointe!
- Graissez la serrure et les charnières chaque année!

(NL) Onderhoud

- Geen chemicaliën in de berging opslaan!
- Zonnebrandolie/melk en andere cremes met water en glansmiddel verwijderen.
- Gebruik geen schuurmiddelen!
- Regelmatig bladeren van dak verwijderen!
- Dakgootuitloop controleren.
- Krassen direct met de meegeleverde lak behandelen.
- Slot jaarlijks oliën

(ES) Cuidado y mantenimiento

- No almacene productos químicos agresivos dentro de la caseta como por ejemplo cloro y sal antiescarcha.
- Evite dejar huellas o restos de cremas solares sobre la chapa. Limpie la caseta siempre con agua y jabón.
- No utilice ningún producto para fregar. En general, evite siempre cualquier producto químico para limpiar la caseta.
- Mantenga el tejado libre de hojas secas.
- Controle el desagüe del canalón.
- Repare los arañazos lo antes posible con el barniz que se incluye.
- Aplique aceite en la cerradura y las bisagras una vez al año.

(IT) Manutenzione

- Non lasciare prodotti chimici aggressivi (come ad esempio cloro o sale per strade) all'interno della casetta!
- Rimuovere crema solare e altre creme con acqua e brillantante!
- Non utilizzare detergenti contenenti sostanze aggressive!
- Mantenere il tetto libero da foglie!
- Controllare la grondaia!
- Ritoccare immediatamente eventuali graffi con la vernice fornita nella confezione!
- Lubrificare la serratura e le cerniere a cadenza annuale!

(DK) Pleje og vedligeholdelse

- Opbevar ikke aggressive stoffer dvs. Klor eller vejsalt!
- Fjern solcreme eller andre typer af creme med vand og rensningsmiddel!
- Brug ikke aggressive rengøringsmidler!
- Hold taget fri for blade!
- Kontroller rendestenen!
- Ved skrammer, brug straks malingen som er stillet til rådighed!
- Smør låsen årligt!



Paket Nr. 1

Türpaket · Doorpackage · Carton de portes · Deurpakket · Kit de puerta · Pacco porta · Dørpakke

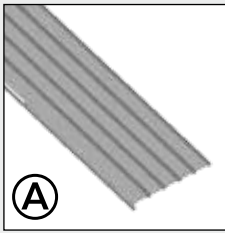

(A)

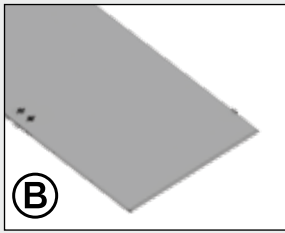

(B)

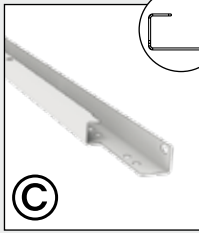

(C)



(D3)

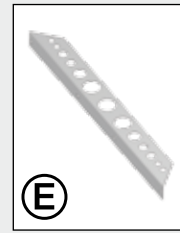

(E)

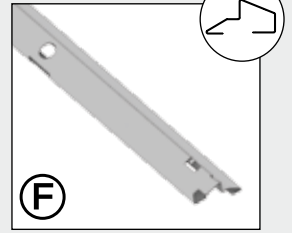

(F)

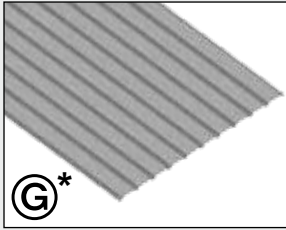

(G*)

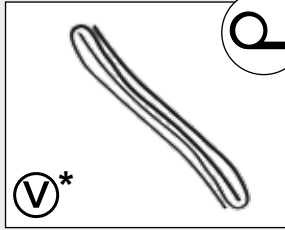

(V*)



(D4)



(H)

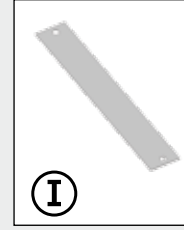

(I)



(J)

*Teil entfällt bei der Doppeltür

- (GB) Part not required when double doors are fitted
- (FR) La pièce est supprimée pour la double portes.
- (NL) Deel vervalt bij de dubbele deur
- (ES) Pieza no es necesaria en caso de puerta doble
- (IT) Pezzo non può essere utilizzato per la variante porta a due battenti
- (DK) Del ikke nødvendig med dobbeltdør

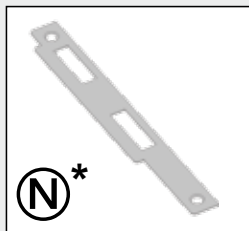

(N*)

Zusatzteile Doppeltür

(double door package · carton de double portes · dubbeldeurpakket · pacco porta doppia · kit de puerta adicional · Ekstradele dobbeltdør)



(ZA)



(K)



Paket Nr. 2

Seitenwandpaket · Side panel package · Carton de parois latérales · Zijwandpakket · Panel la teral · Pacco pareti laterali · Sidepladepakke

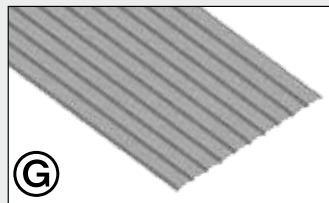

(G)



Paket Nr. 2a

Seitenwandpaket · Side panel package · Carton de parois latérales · Zijwandpakket · Panel la teral · Pacco pareti laterali · Sidepladepakke

Nur für Größe XL

Only for size XL
Uniquement pour taille XL
Alleen voor maat XL
Sólo para los tamaños XL
Solo per misura XL
Kun for størrelse XL

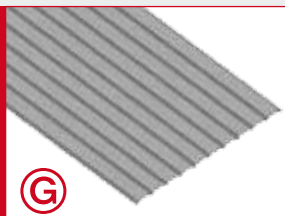

(G)



Paket Nr. 3

Profilpaket · Profile package · Carton de profils · Profielpakket · Kit de perfiles · Pacco profili · Profilpakke



(D1)



(D2)

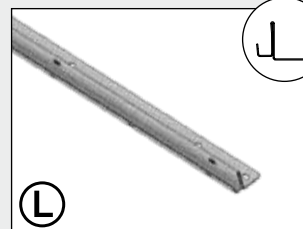

(L)

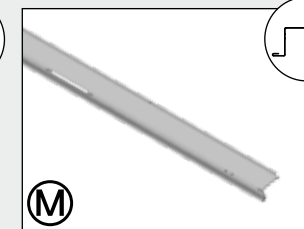

(M)

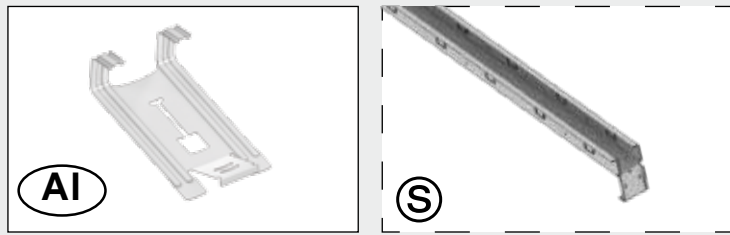
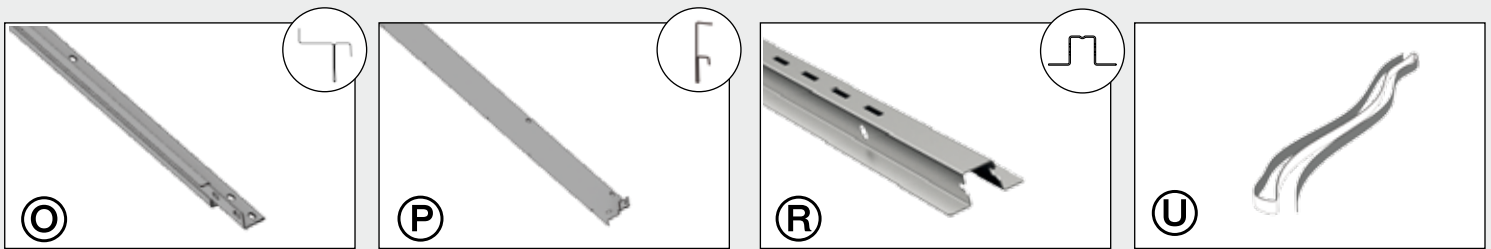

Teil ③ entfällt bei Größe XL

- Ⓒ Part ③ does not apply to size XL
- Ⓕ La partie ③ ne s'applique pas à la taille XL
- Ⓖ Deel ③ is niet van toepassing op maat XL
- Ⓔ Parte ③ no se aplica a tamaño XL
- Ⓘ Parte ③ non si applica alla taglia XL
- Ⓙ Del ③ er ikke nødvendig til størrelse XL

Teil AN, AS und AQ zusätzlich bei Größe XL

- Ⓒ Part AN, AS and AQ additional for size XL
- Ⓕ Partie AN, AS et AQ supplémentaires pour la taille XL
- Ⓖ Deel AN, AS en AQ extra voor maat XL
- Ⓔ Parte AN, AS y AQ adicionales para el tamaño XL
- Ⓘ Parte AN, AS e AQ supplementare per il formato XL
- Ⓙ Del AN, AS og AQ desuden for størrelse XL



4 Paket Nr. 4

Dach-Blechpaket · Roof panel package · Carton de tôles de toit · Dakplaatpakket · Pacco lamiera tetto · Kit de tejado laminado · Tagpladepakke

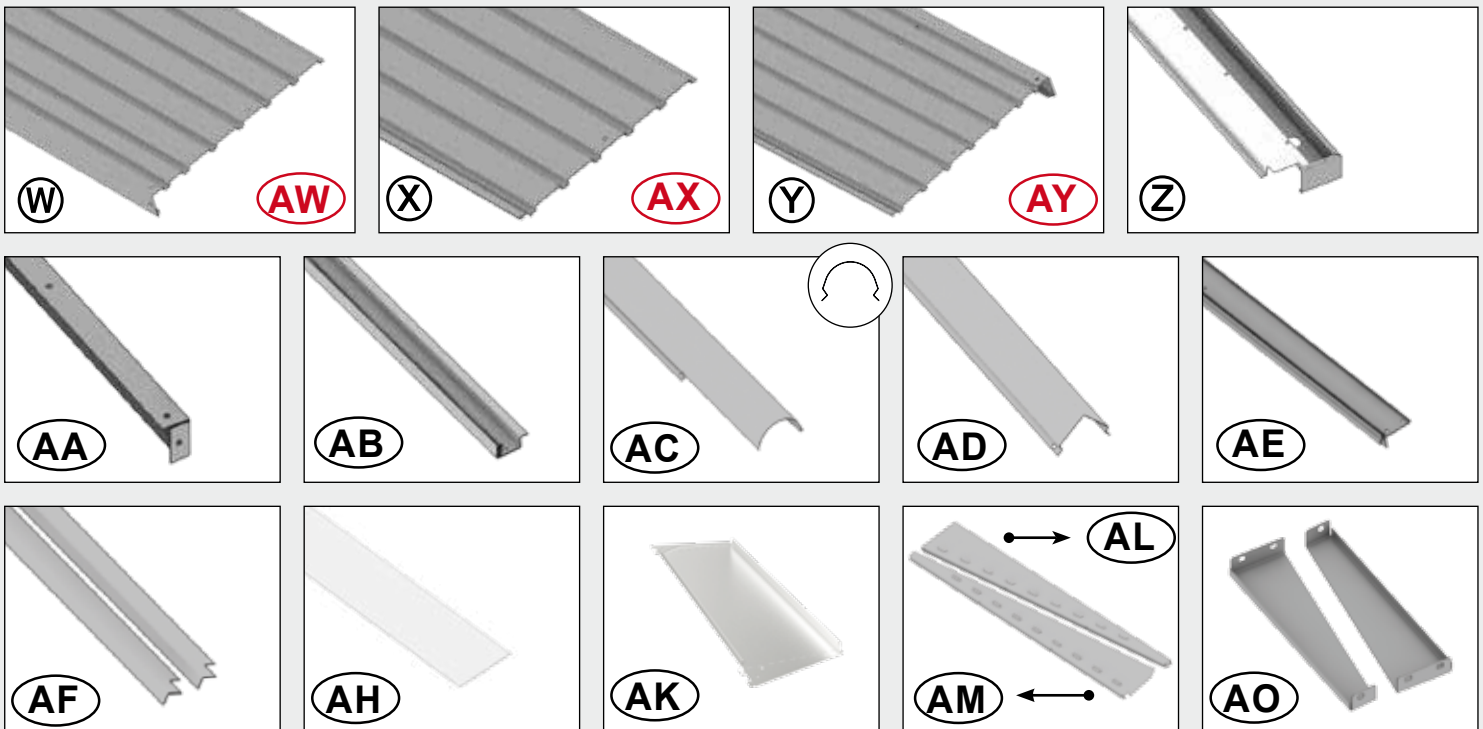

Bodenrahmen

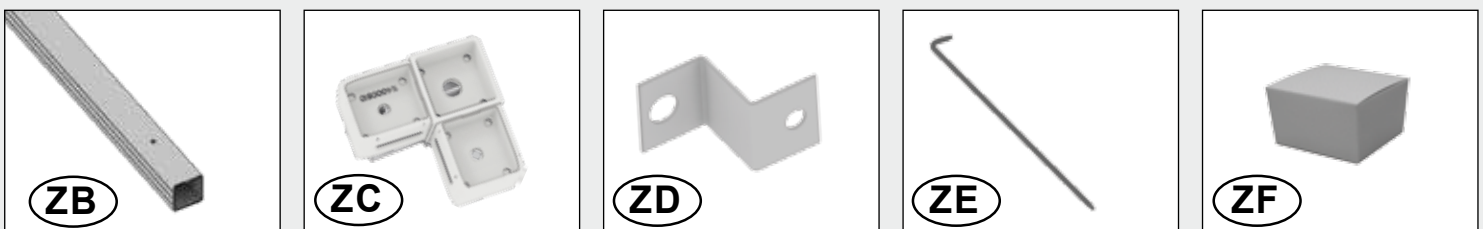

Floor Frame - Cadre de sol - Bodemframe - Marco de suelo - Telaio perimetrale - Bundramme



Rückwand

Rear wall - Paroi arrière - Achterwand - Panel posterior - Parete posteriore - Bagplade

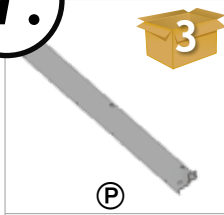
1.

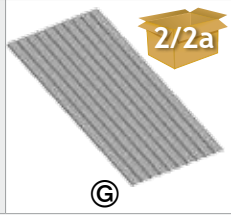
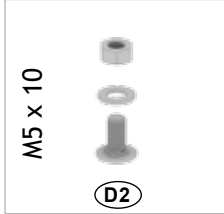
 <p>Ⓟ</p>	<p>M: 1x (1710mm) L: 1x (2510mm) XL: 1x (2510mm)</p>	 <p>Ⓛ</p>	<p>M: 1x (1710mm) L: 1x (2510mm) XL: 1x (2510mm)</p>	 <p>ⓐ</p>	<p>M: 2x L: 3x XL: 3x</p>
<p>M5 x 10</p>  <p>ⓓ2</p>	<p>M: 4x L: 8x XL: 8x</p>				

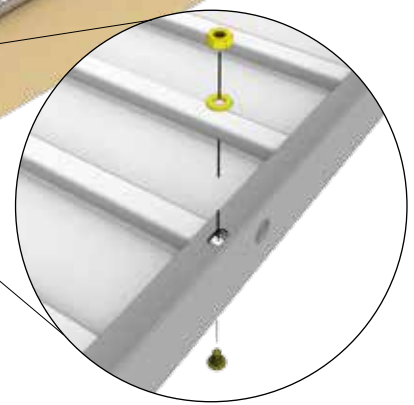
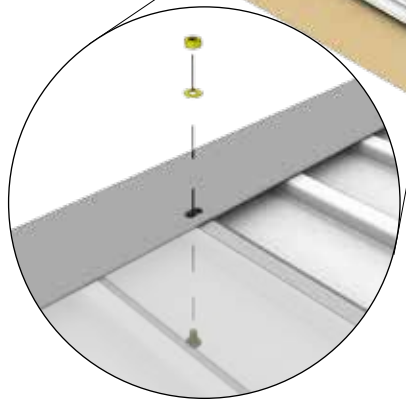
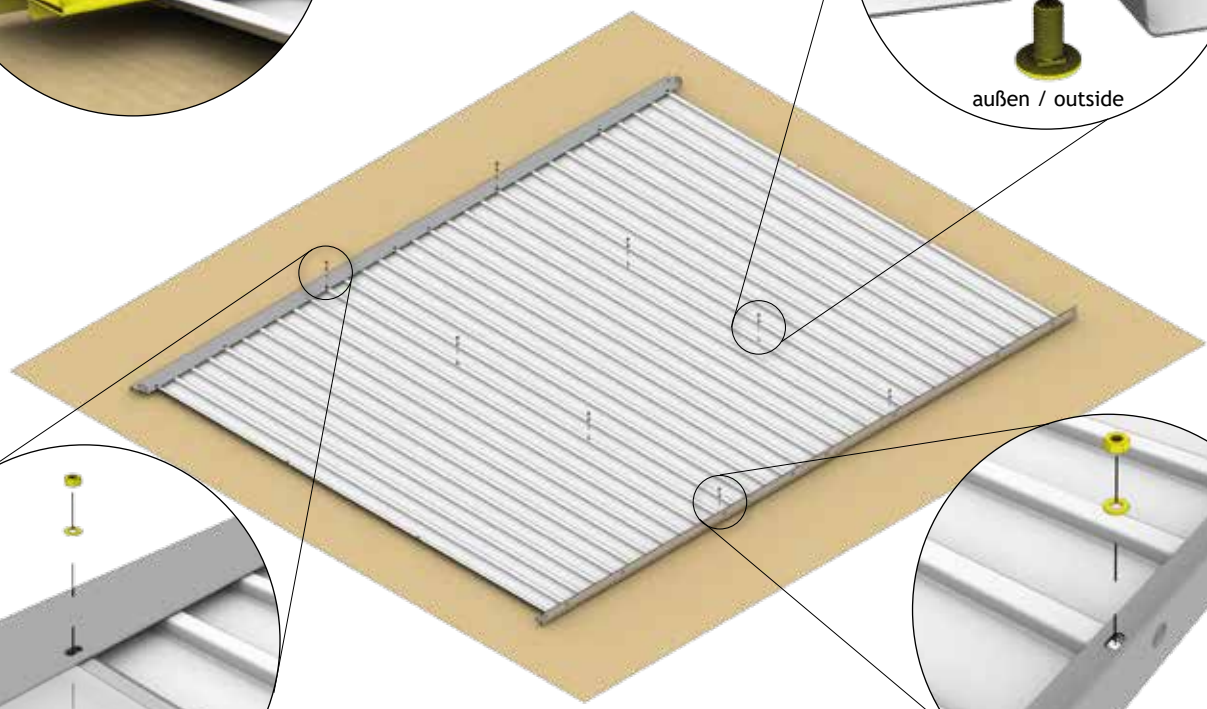
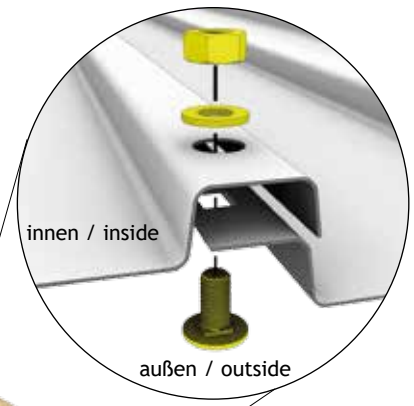
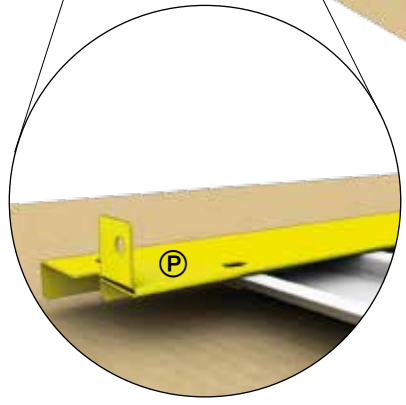
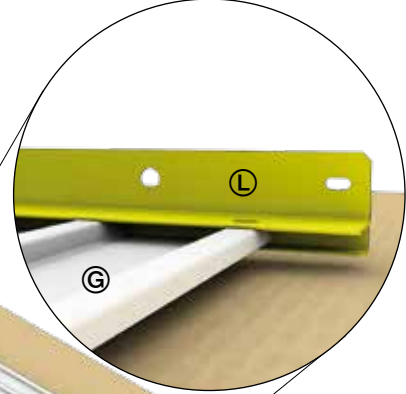
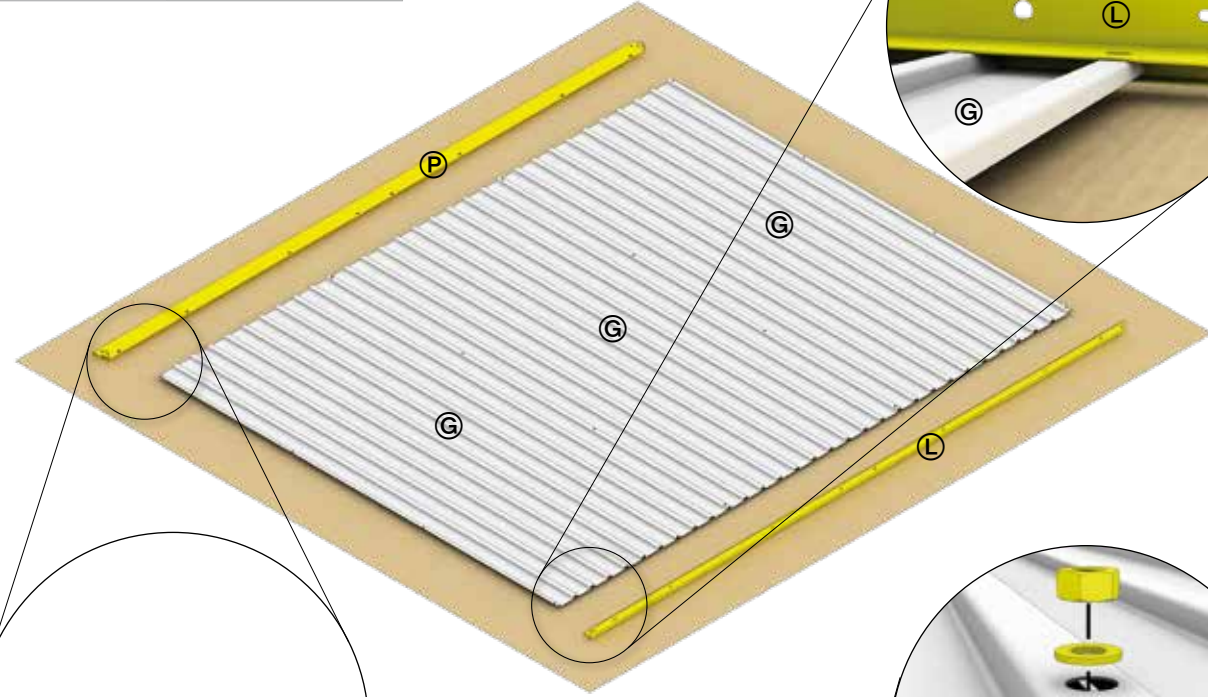



Doppeltür

Double Door - Deuxième battant de porte - Tweede deurvleugel - Secondo battente - Puerta doble - Dobbeltjør



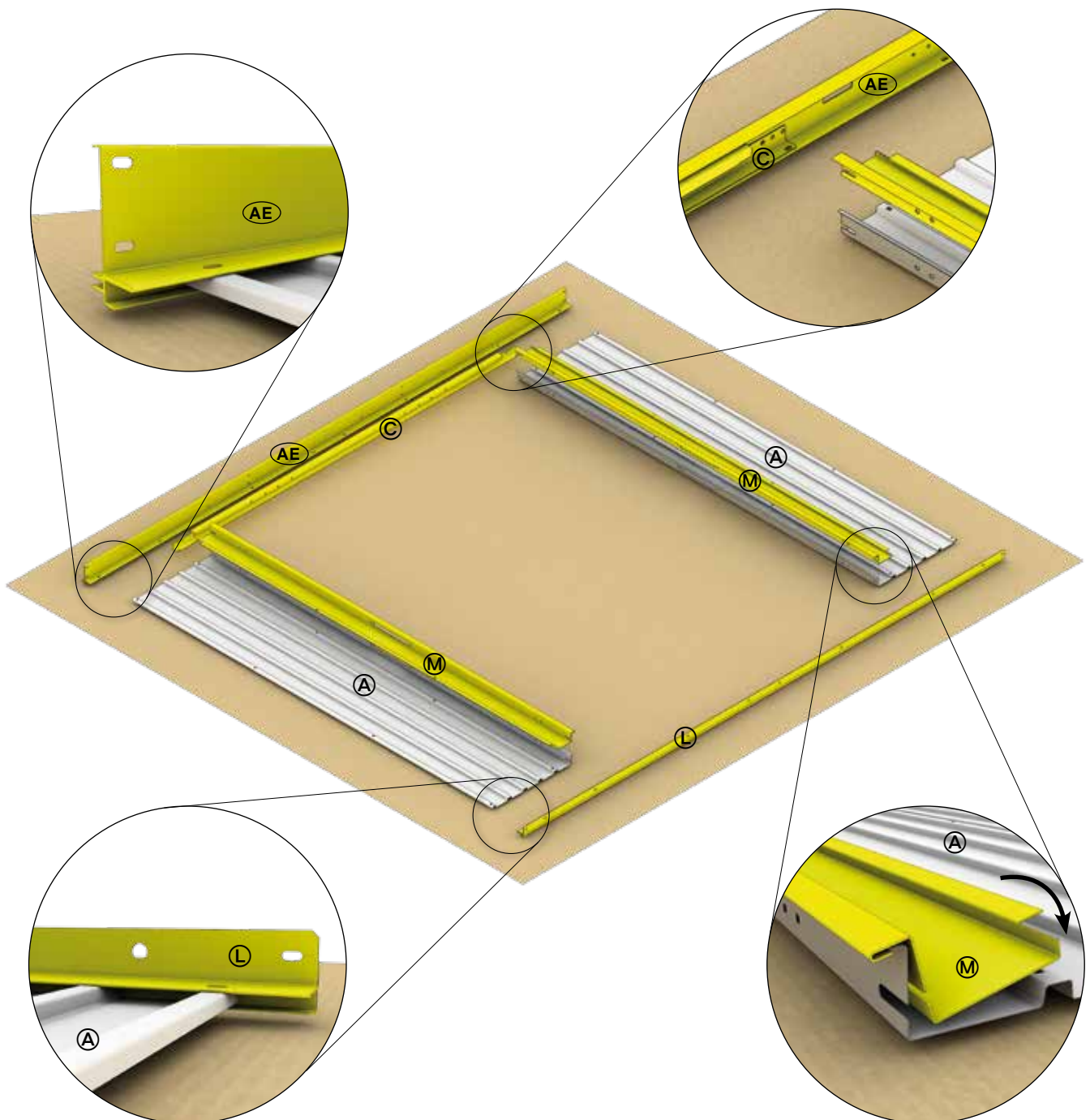



<p>1</p> <p>L: 2x XL: 2x</p> <p>(A)</p>	<p>4</p> <p>L: 1x (2510mm) XL: 1x (2510mm)</p> <p>(AE)</p>	<p>3</p> <p>L: 2x XL: 2x</p> <p>(M)</p>
<p>3</p> <p>L: 1x (2510mm) XL: 1x (2510mm)</p> <p>(L)</p>	<p>1</p> <p>L: 1x (1784mm) XL: 1x (1784mm)</p> <p>(C)</p>	

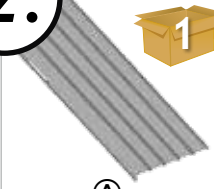

2.



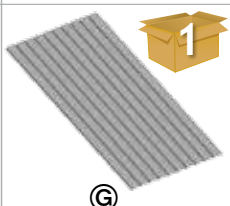

Standardtür

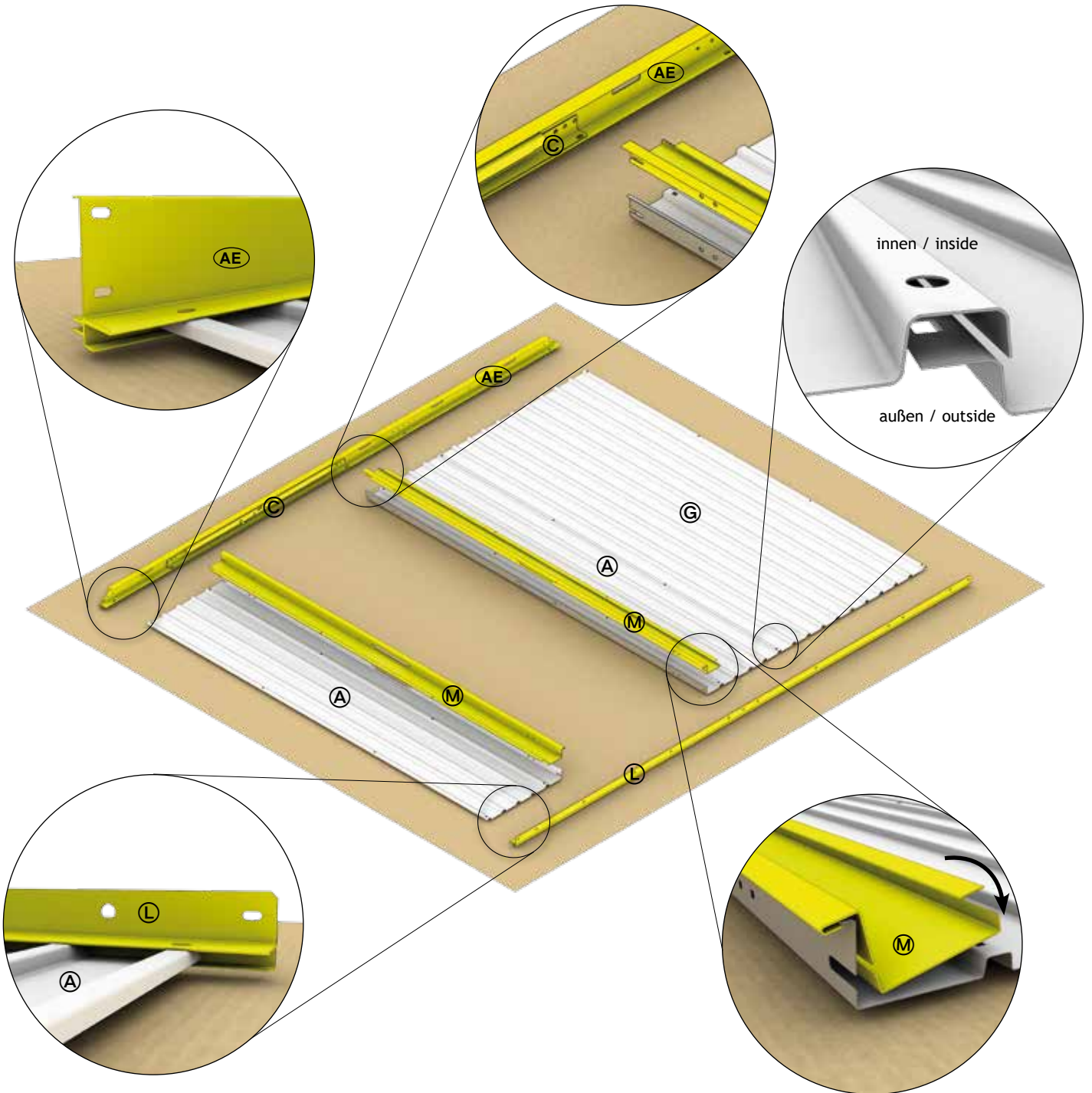
Standard door - Porte standard - Standaard deur - Puertas estándar - Porta standard - Standarddør

 <p>1</p> <p>M: 2x L: 2x XL: 2x</p> <p>(A)</p>	 <p>4</p> <p>M: 1x (1710mm) L: 1x (2510mm) XL: 1x (2510mm)</p> <p>(AE)</p>	 <p>3</p> <p>M: 2x L: 2x XL: 2x</p> <p>(M)</p>
 <p>3</p> <p>M: 1x (1710mm) L: 1x (2510mm) XL: 1x (2510mm)</p> <p>(L)</p>	 <p>1</p> <p>L: 1x XL: 1x</p> <p>(G)</p>	 <p>1</p> <p>M: 1x (984mm) L: 1x (984mm) XL: 1x (984mm)</p> <p>(C)</p>



M5 x 10		M: 10x
		L: 14x
		XL: 14x
		



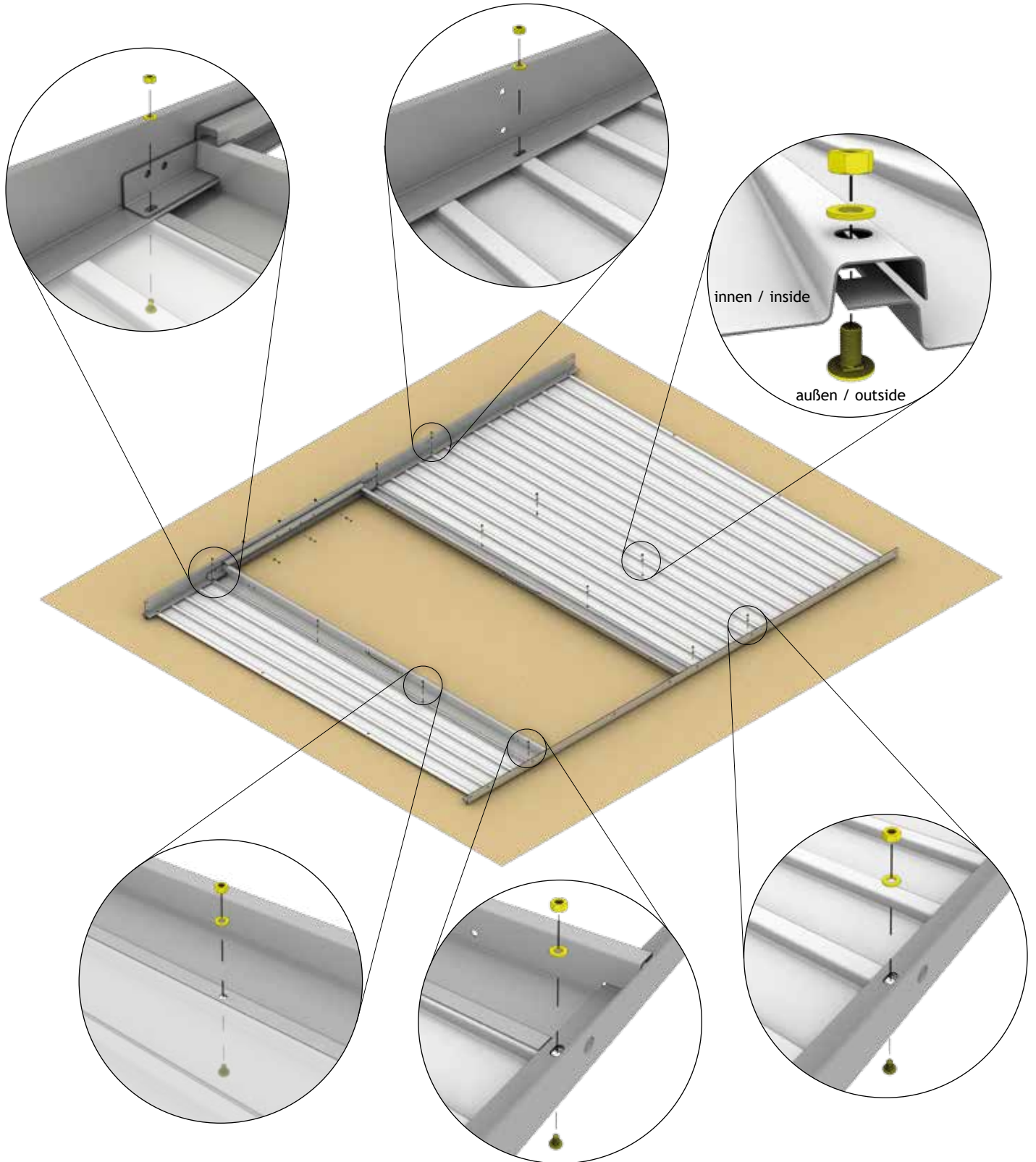

Doppeltür <i>Double Door - Deuxième battant de porte - Tweede deurvleugel - Secondo battente - puerta doble - Dobbeltjør</i>	M5 x 10	   	L: 12x
			XL: 12x



Seitenwand

Side wall - Paroi latérale - Zijwand - panel lateral - Parete laterale - Sideplade

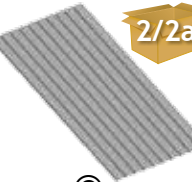
3.

	<p>3</p> <p>M: 2x (1710mm) L: 2x (1710mm) XL: 2x (2510mm)</p>		<p>3</p> <p>M: 2x (1710mm) L: 2x (1710mm) XL: 2x (2510mm)</p>		<p>2/2a</p> <p>M: 4x L: 4x XL: 6x</p>
<p>M5 x 10</p> 	<p>M: 4x L: 4x XL: 8x</p>				

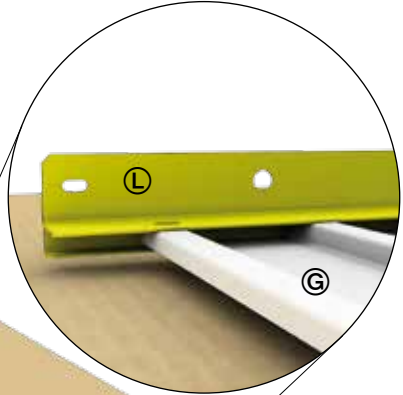

2x

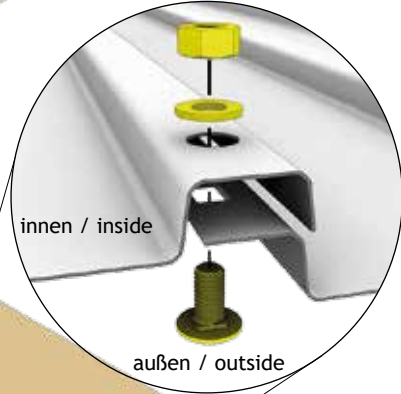
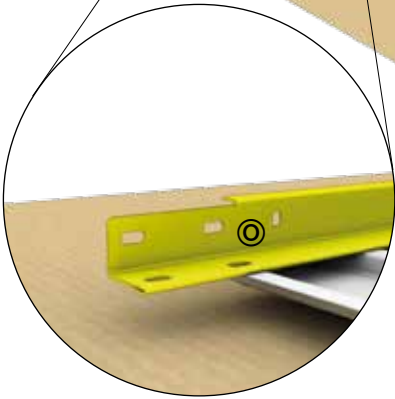
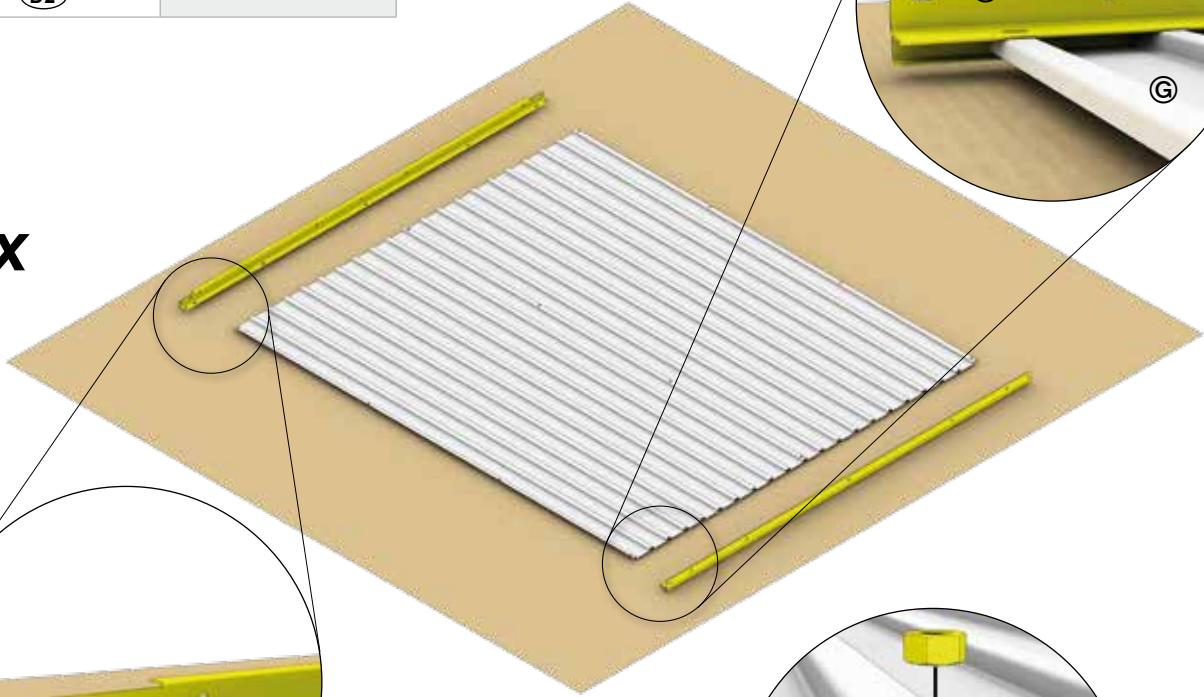

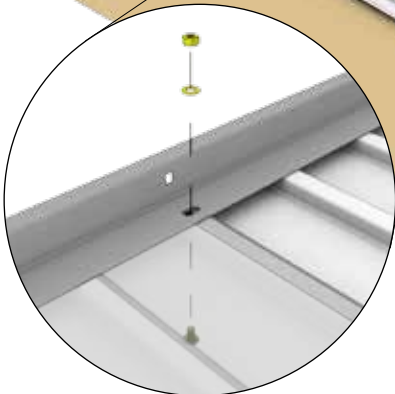
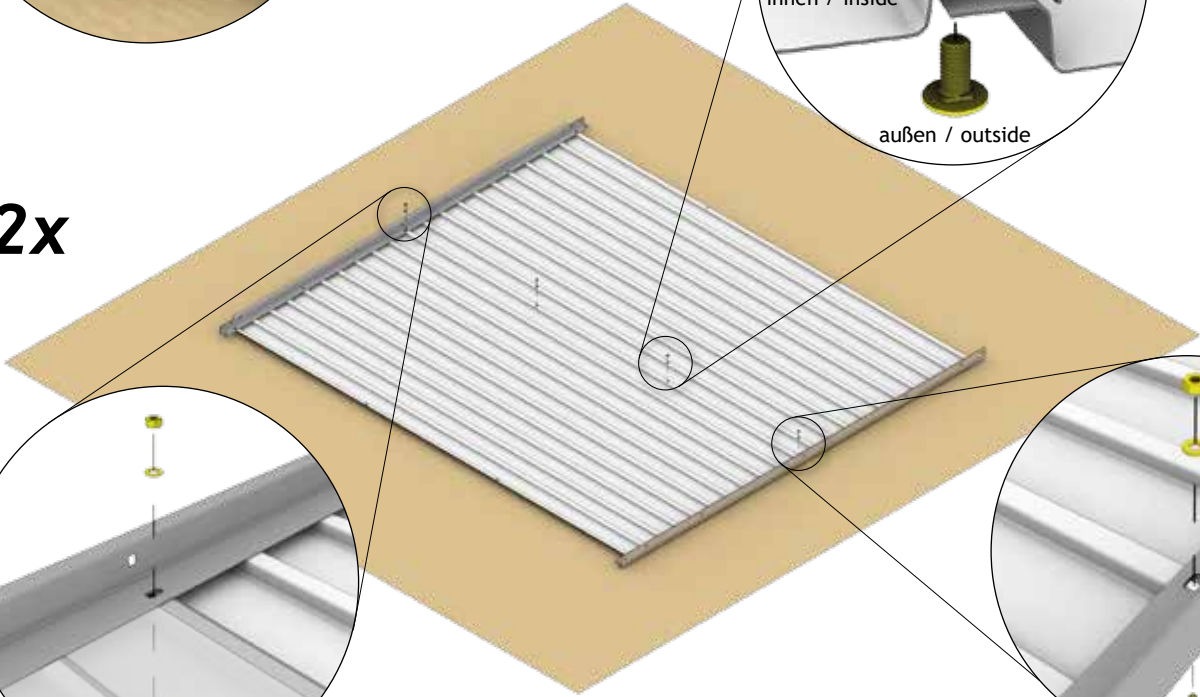

2x





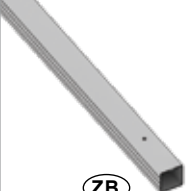

Bodenrahmen

Floor Frame - Cadre de sol - Bodemframe - Marco de suelo - Telaio perimetrale - Bundramme

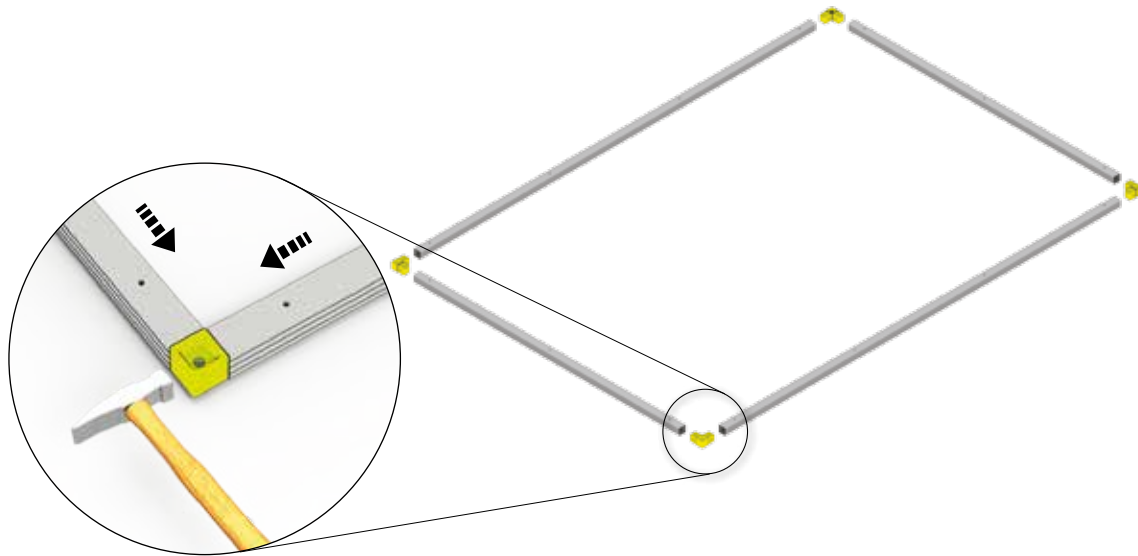
 <p>ZB</p>	M: 4x (1640mm)	 <p>ZC</p>	M: 4x
	L: 2x (1640mm)		L: 4x
	2x (2440mm)		XL: 4x
	XL: 4x (2440mm)		



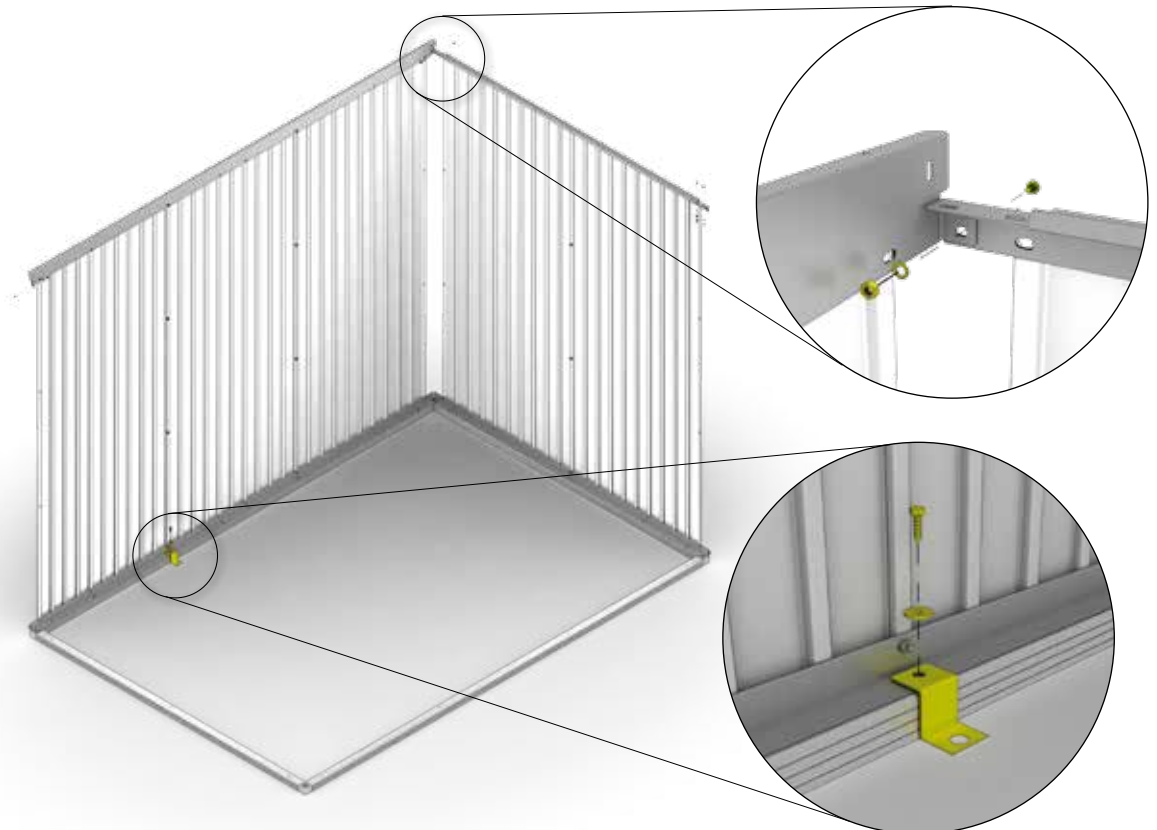

 <p>ZD</p>	M: 1x	<p>6,3 x 22</p>  <p>ZF</p>	M: 1x	<p>M5 x 10</p>  <p>D2</p>	M: 1x
	L: 1x		L: 1x		
	XL: 1x		XL: 1x		
					L: 1x
					XL: 1x





Bodenrahmen



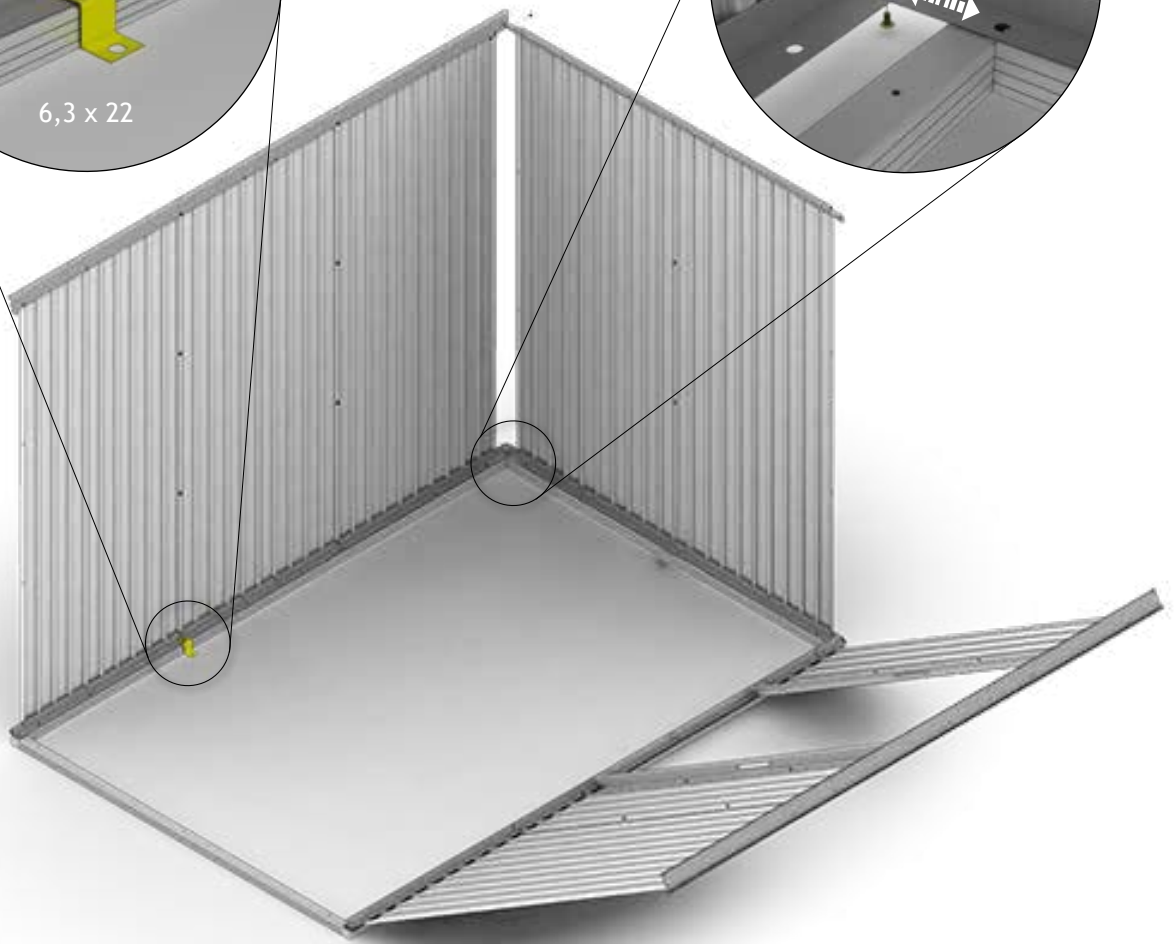
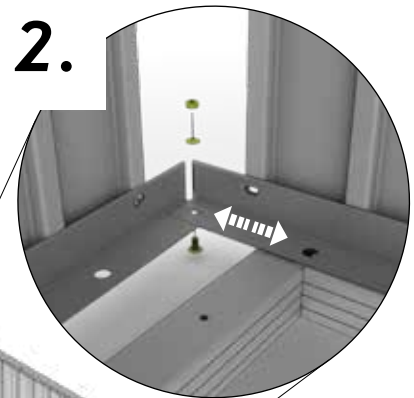
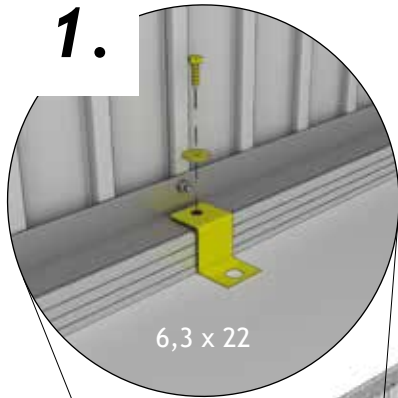

Floor Frame - Cadre de sol - Bodemframe - Marco de suelo - Telaio perimetrale - Bundramme

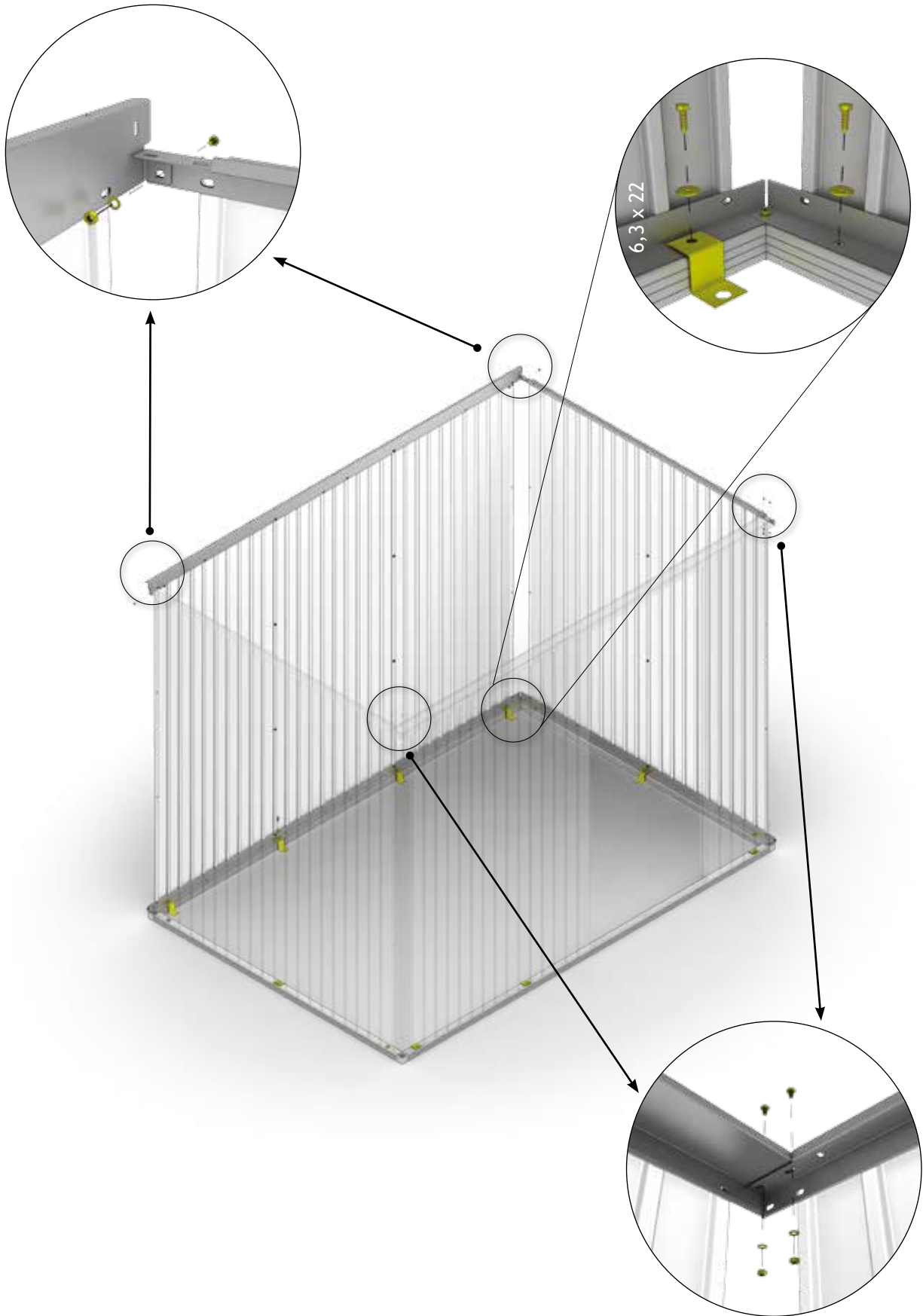
 <p>ZD</p>	<p>M: 6x L: 8x XL: 10x</p>	<p>M5 x 10</p>  <p>D2</p>	<p>M: 9x L: 9x XL: 9x</p>	<p>6,3 x 22</p>  <p>ZF</p>	<p>M: 6x L: 8x XL: 10x</p>
--	------------------------------------	---	-----------------------------------	--	------------------------------------





4.

M5 x 10		M: 10x
		L: 10x
		XL: 10x
		

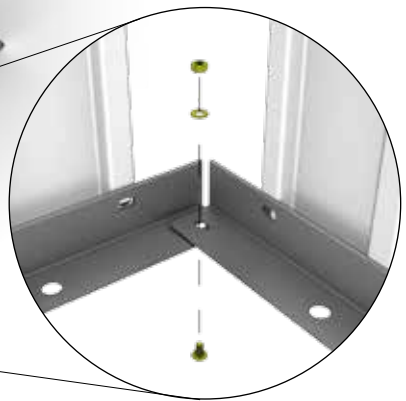
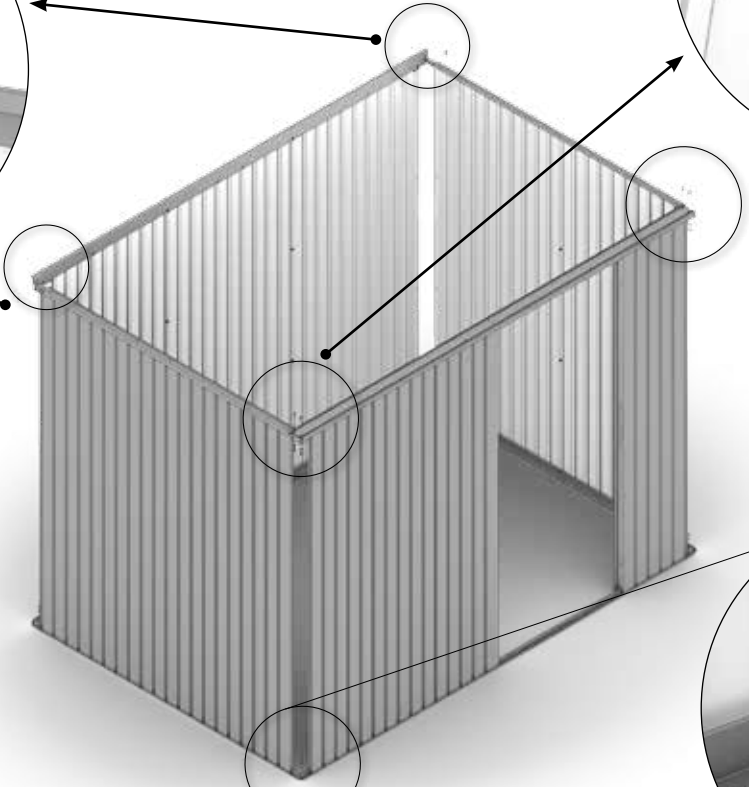
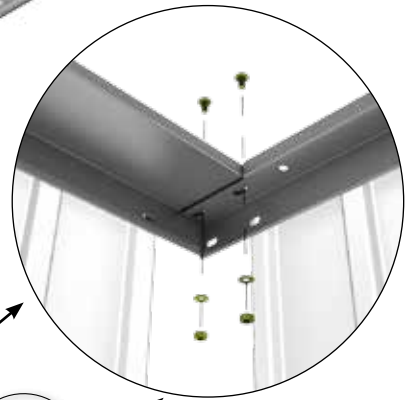
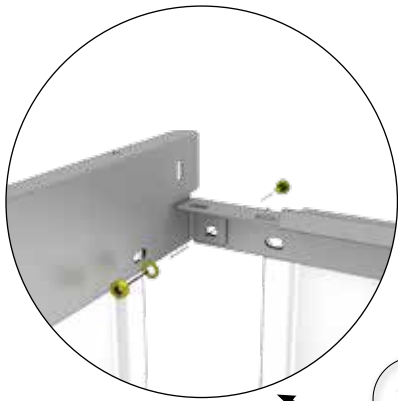
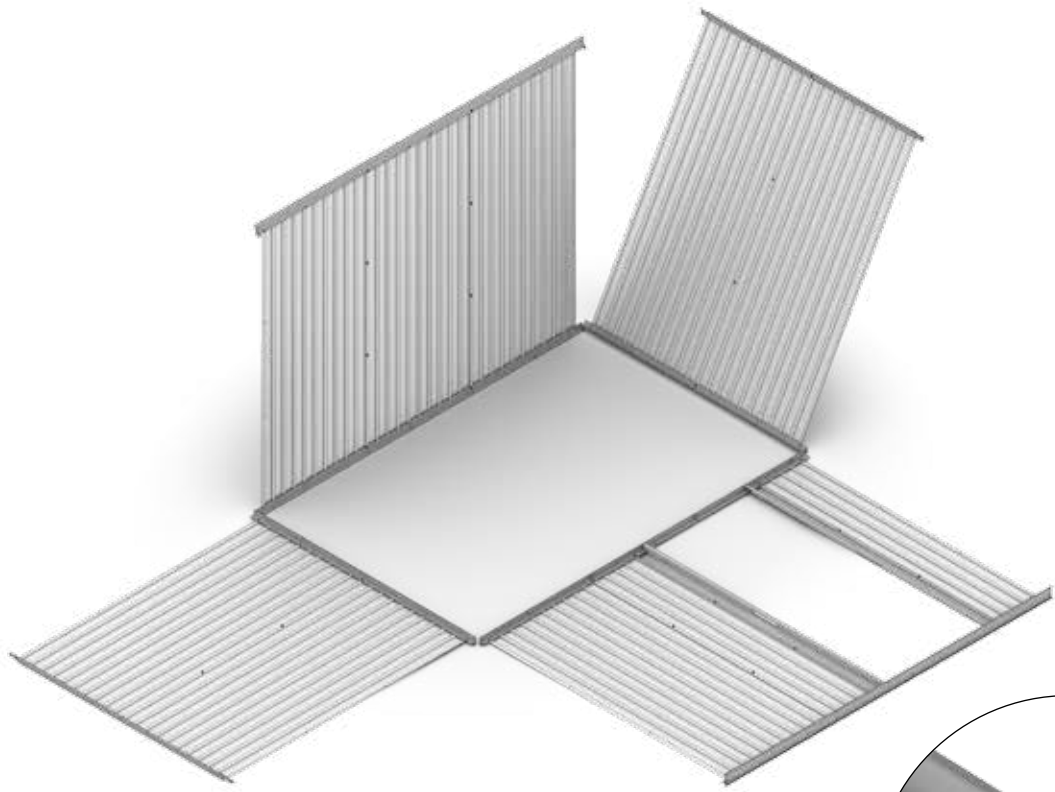



Nur für Größe XL

Only for size XL - Uniquement pour taille XL - Alleen voor maat XL - Sólo para el tamaño XL - Solo per misura XL - Kun for størrelse XL

 3 XL: 1x (2530mm)	 3 XL: 1x (2530mm)	M5 x 10 XL: 20x
 3 XL: 1x	 3 XL: 4x	

1.

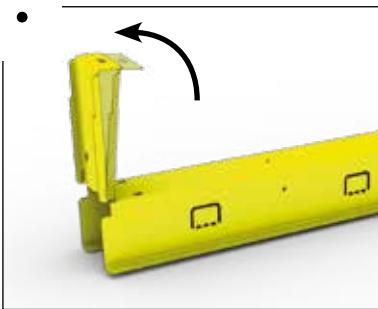

2.

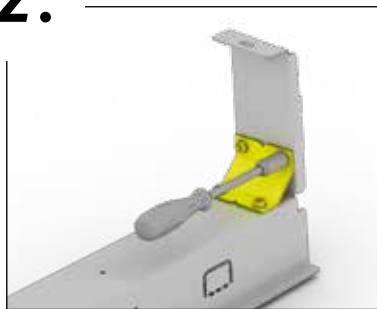

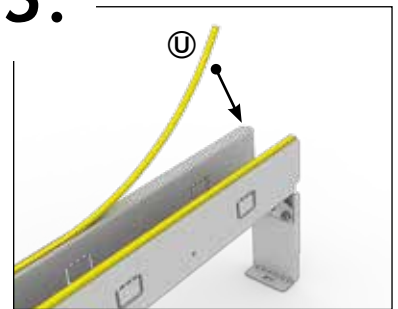

3.

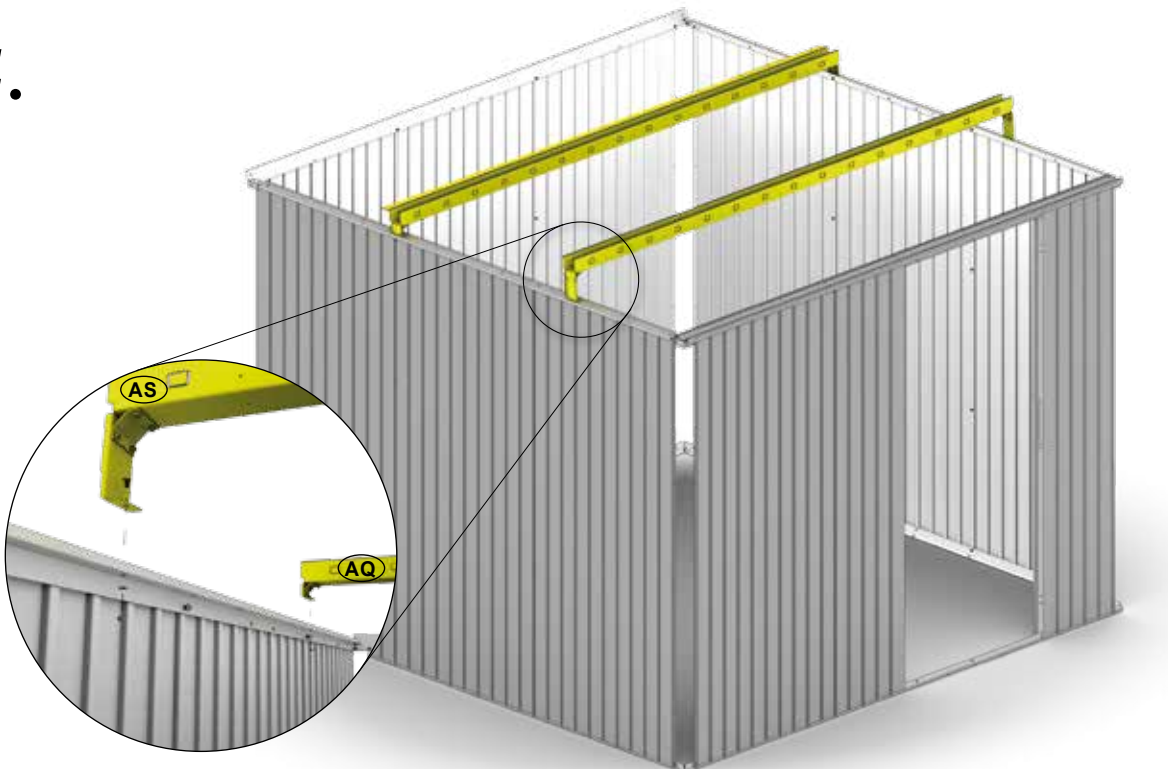

4.



<p>5.</p>  <p>Ⓢ</p>	<p>M: 1X (1730mm) L: 1X (2530mm)</p>	 <p>Ⓤ</p>	<p>M: 1x L: 1x</p>	<p>M5 x 10</p>  <p>ⓓ2</p>	<p>M: 2x L: 2x</p>
---	--	--	------------------------	--	------------------------

1.

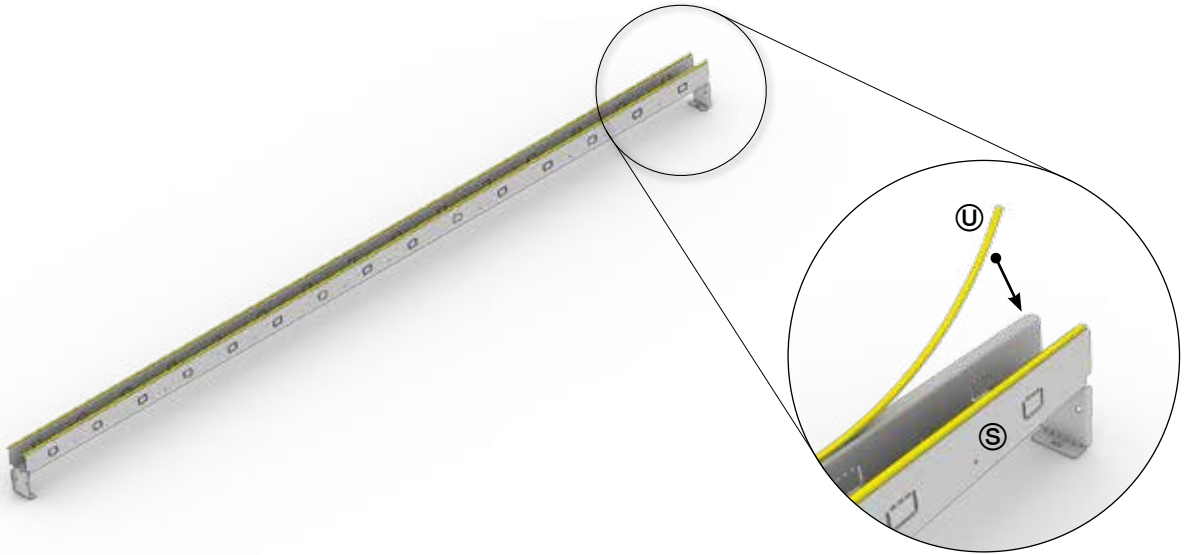

2.

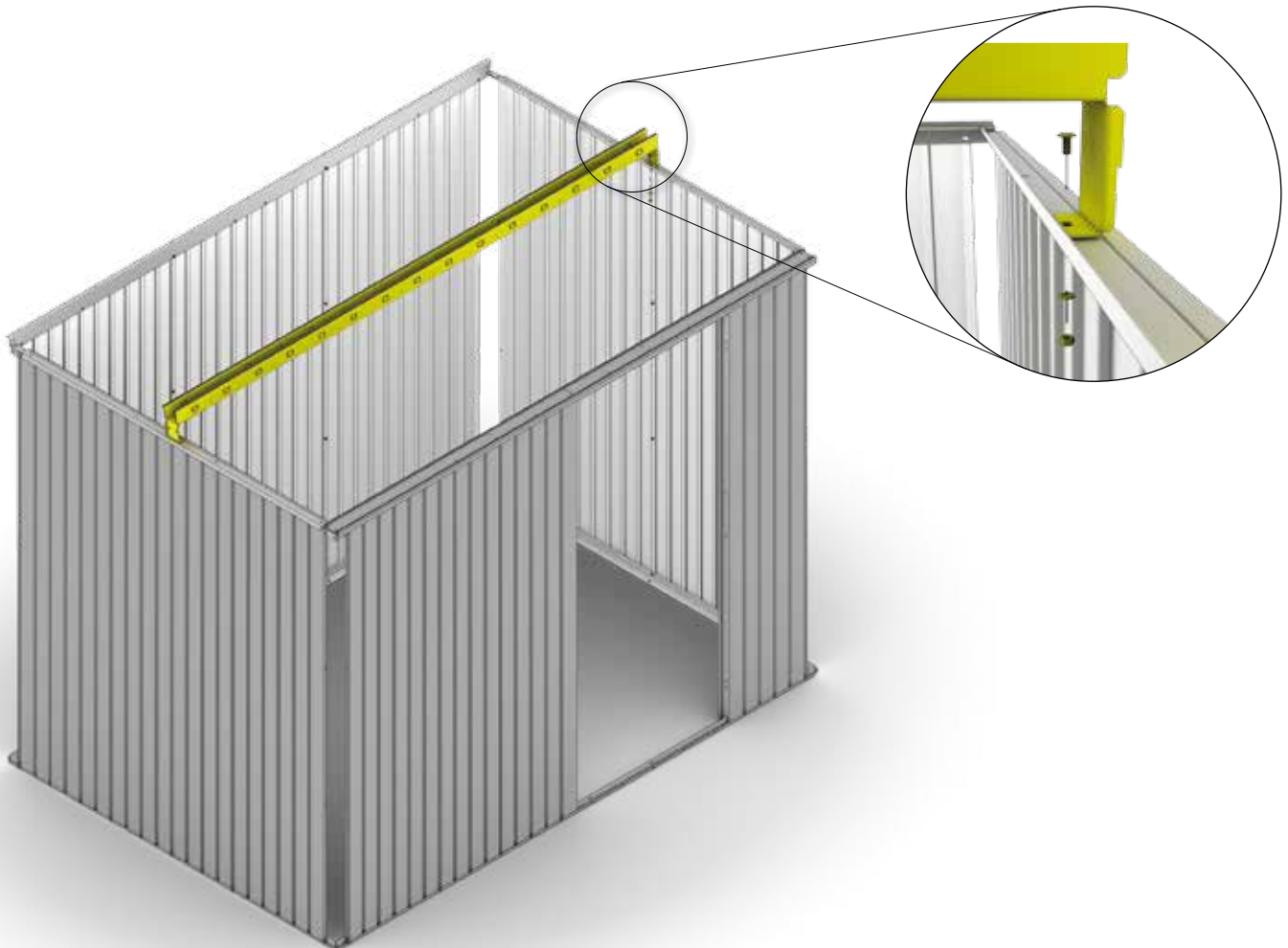

6.

4

M: 1X (1730mm)

L: 1X (2530mm)

XL: 1X (2530mm)

AH



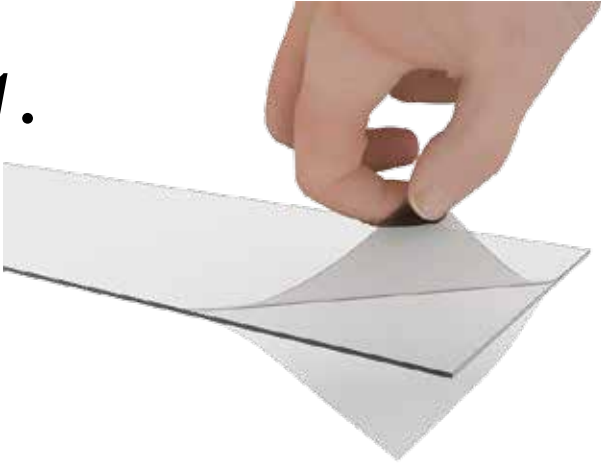

1.

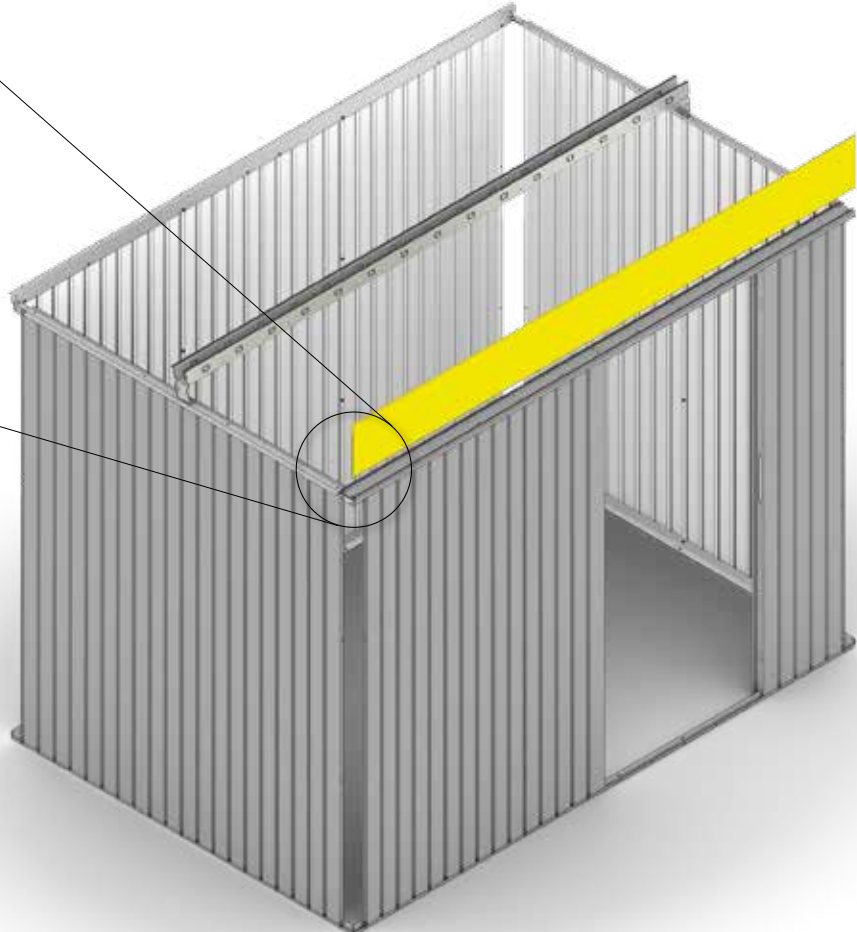
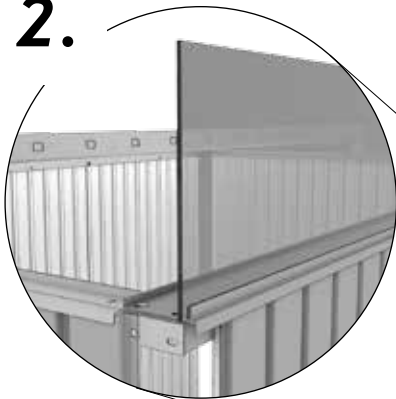

2.



7.

 AB	 4	M: 1X (1730mm)	 U	 3	M: 1X
		L: 1X (2530mm)		L: 1X	
		XL: 1X (2530mm)		XL: 1X	

1.

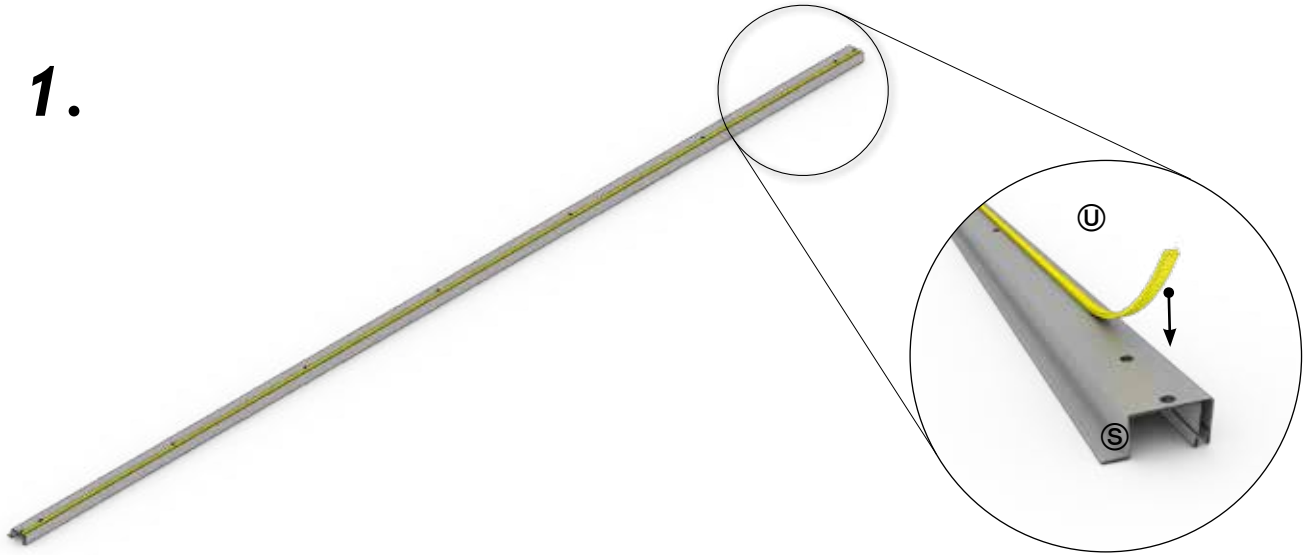

2.

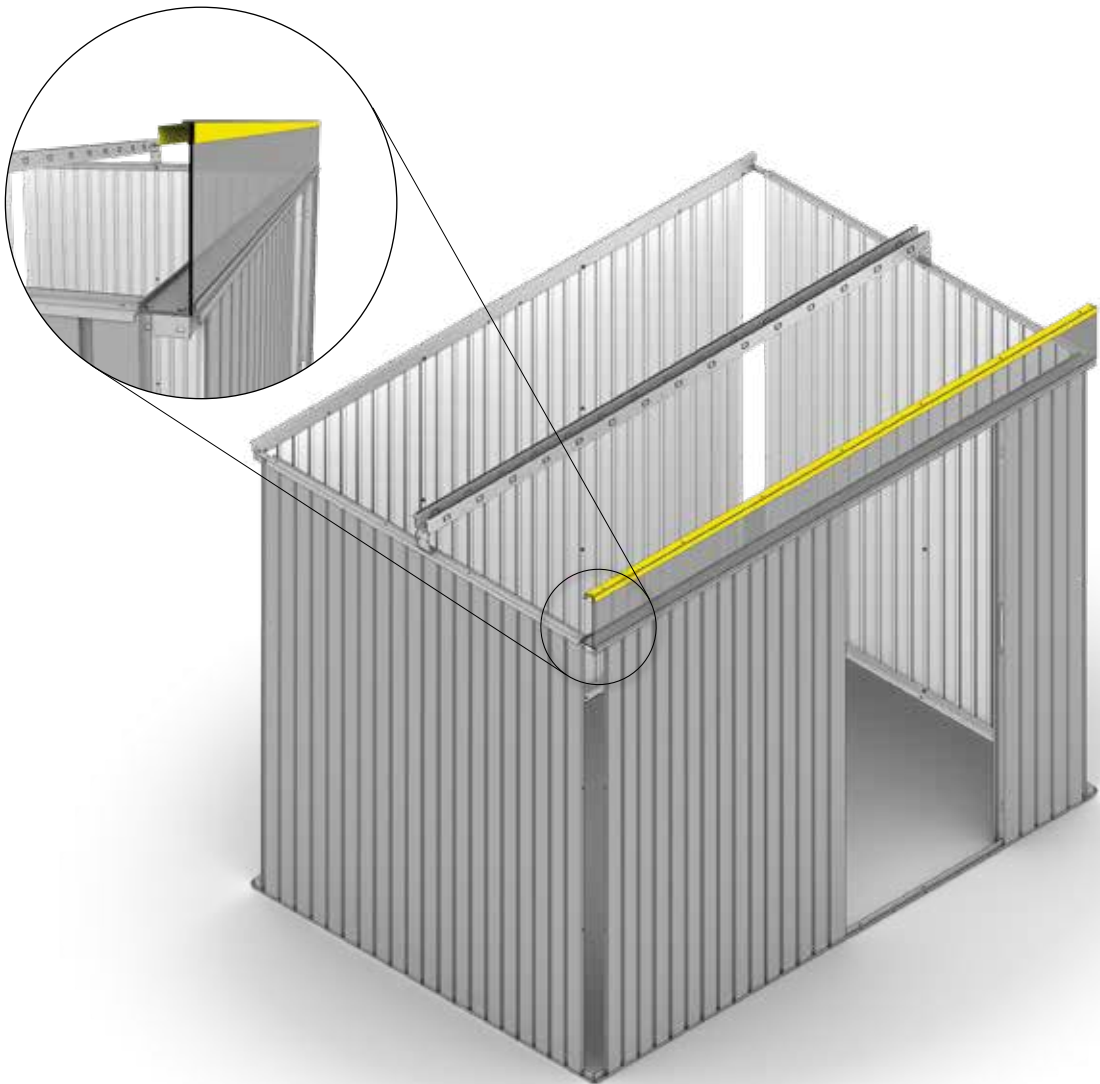

8.

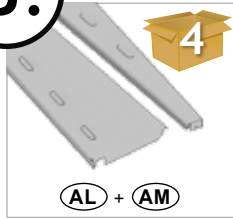

M: 2x (1720mm)
L: 2x (2520mm)
XL: 2x (2520mm)

M5 x 10



M: 10x
L: 10x
XL: 10x

1.

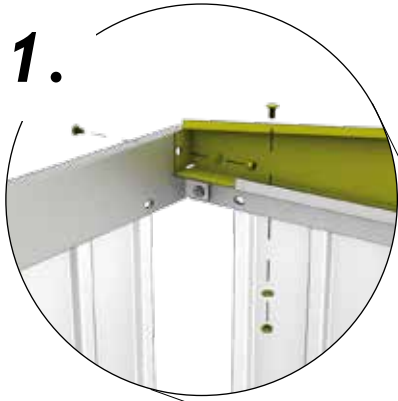

2.



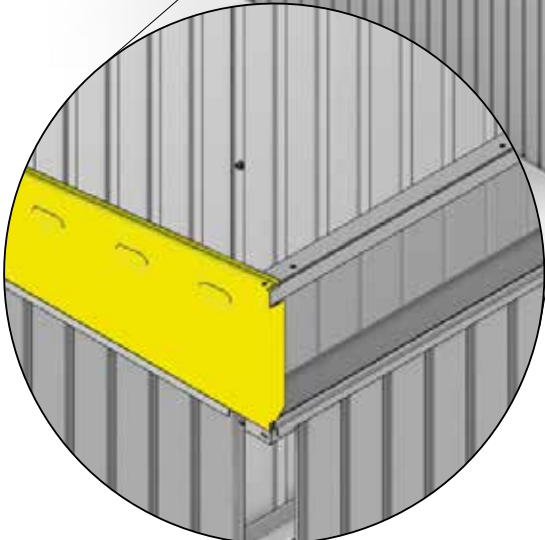

AL



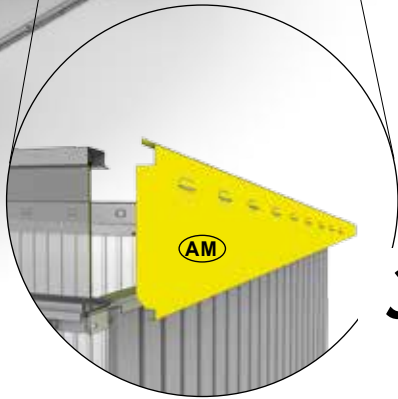

3.



9.

 4 (AD)	M: 2x L: 2x XL: 2x
 (D1)	M: 2x L: 2x XL: 2x

 4 (AC)	M: 2x L: 2x XL: 2x
--	--------------------------

M5 x 10  (D2)	M: 32x L: 32x XL: 32x
---	-----------------------------

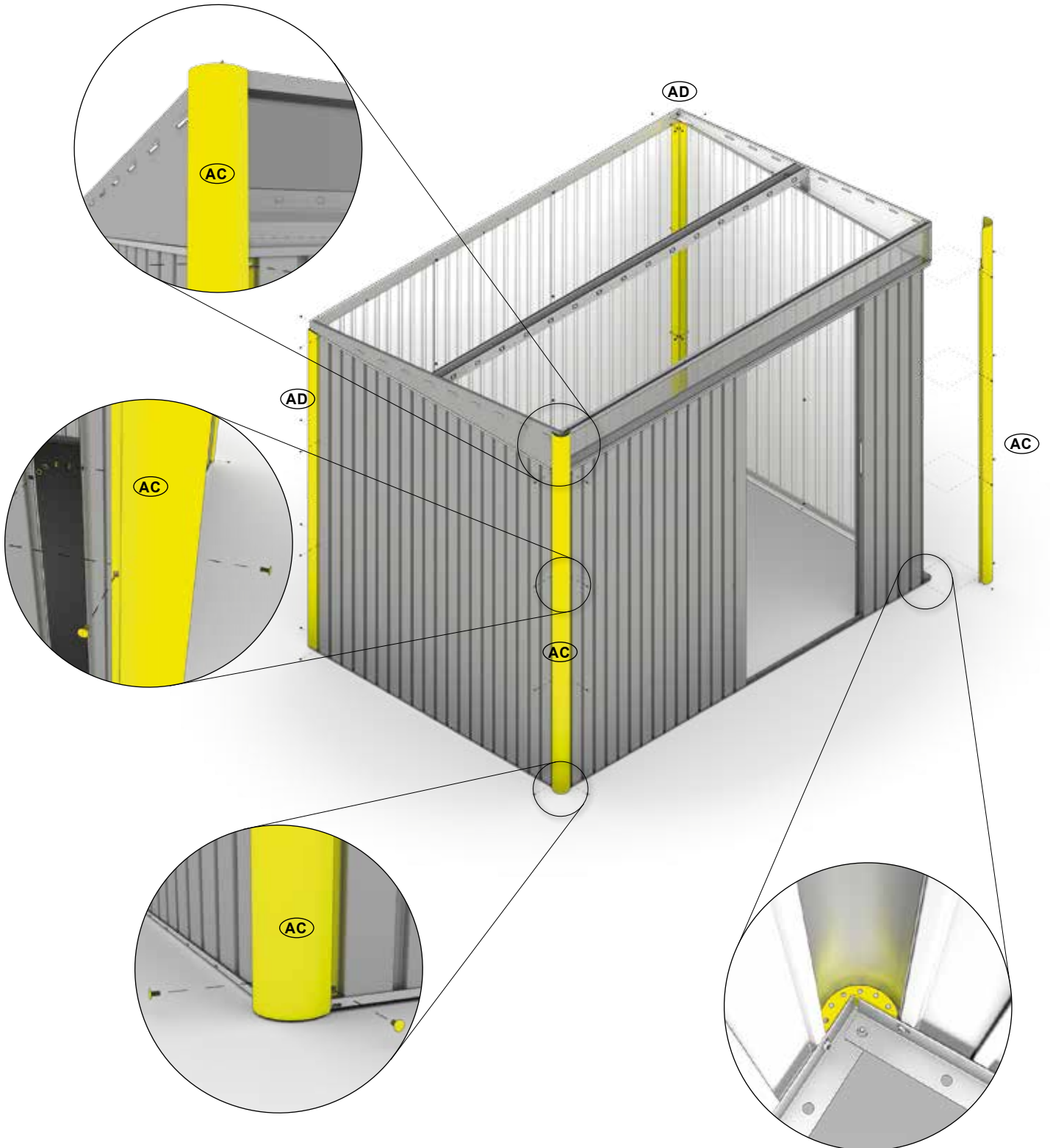

10.

4

M: 2x (1680mm)

L: 2x (1680mm)

XL: 2x (2480mm)

AF

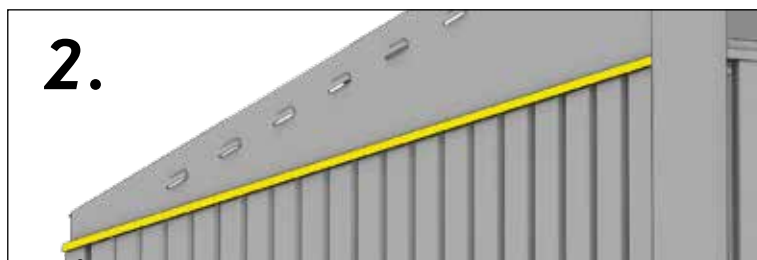
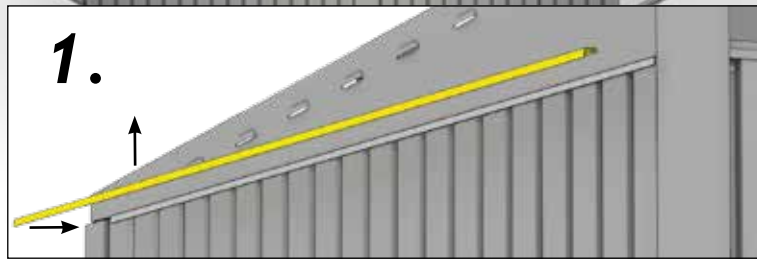
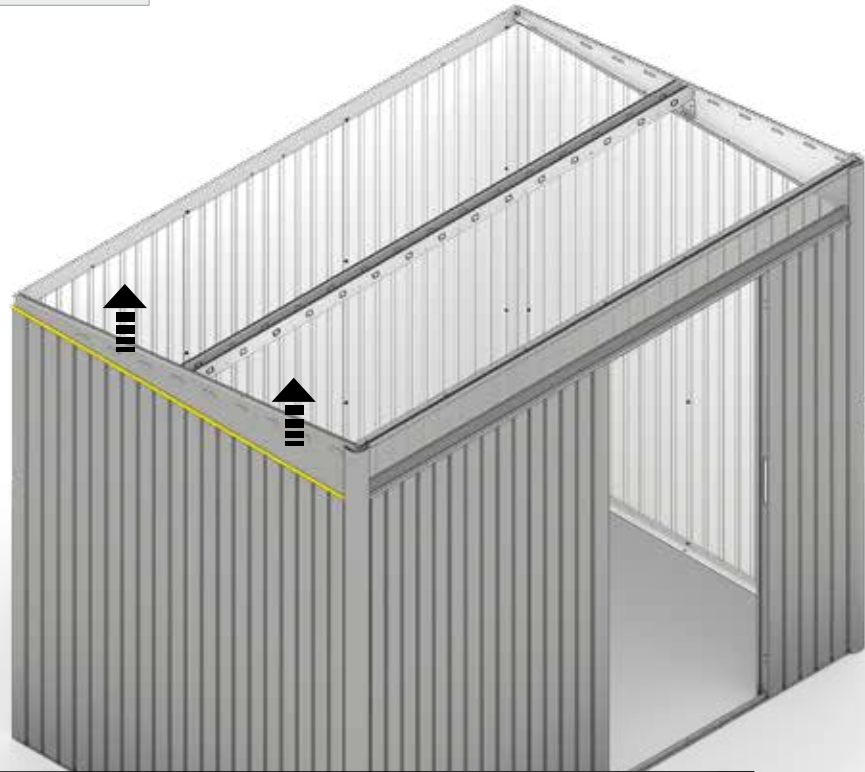

11.

4

M: 1X (1800mm)

L: 1X (2600mm)

XL: 1X (2600mm)

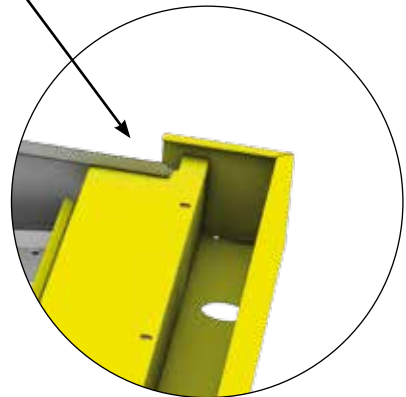
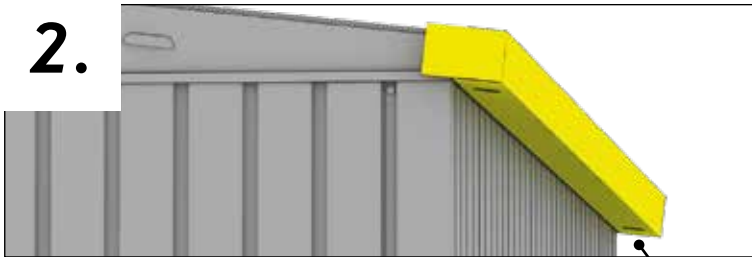
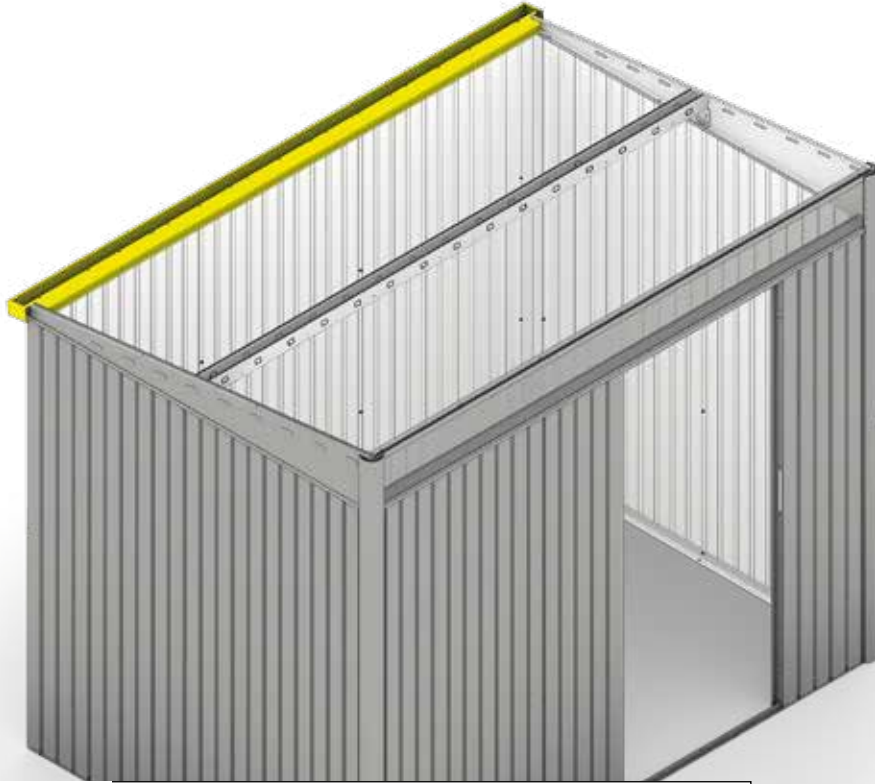
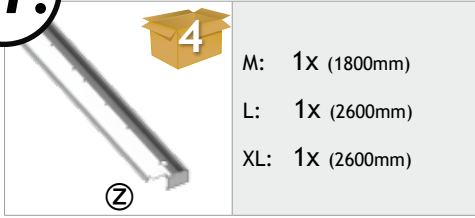



Nur für Größe XL

Only for size XL - Uniquement pour taille XL - Alleen voor maat XL - Sólo para el tamaño XL - Solo per misura XL - Kun for størrelse XL

	XL: 1x (940mm) 1x (2150mm)		XL: 4x (940mm) 4x (2150mm)		XL: 1x (940mm) 1x (2150mm)
	XL: 2x	M5 x 10 	XL: 46x	4,8 x 13 	XL: 2x

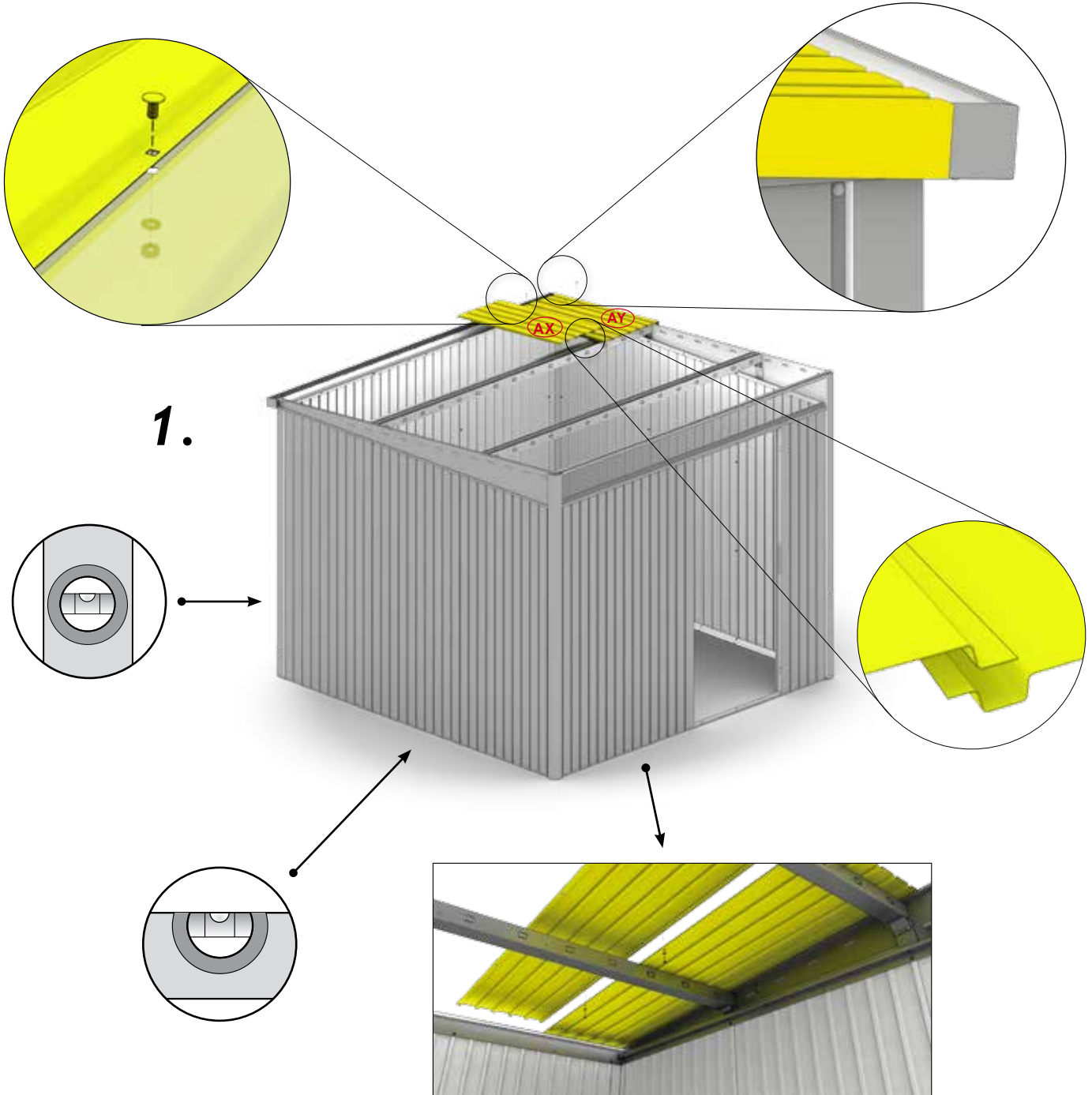

Rechtwinkelig einrichten

- ⒸB rectangular adjusted
- ⒻR ajuster en forme rectangulaire
- ⒸL rechthoekig instellen
- ⒸS ajustar en forma rectangular
- ⒸI mettere in squadra
- ⒸK indstil vinkelret

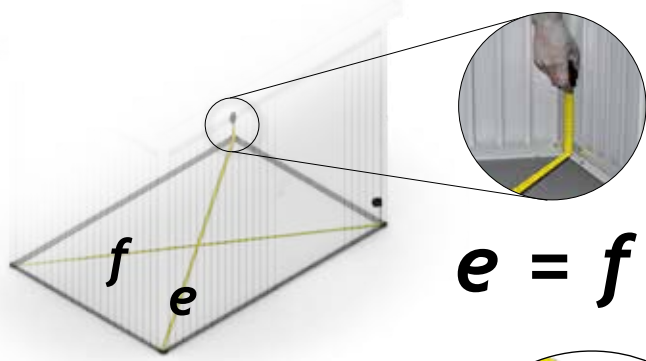

2.

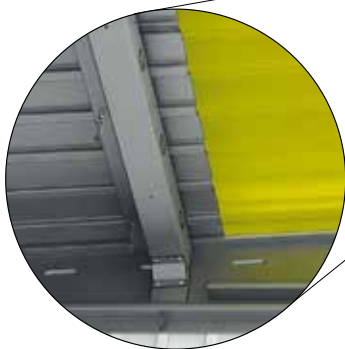
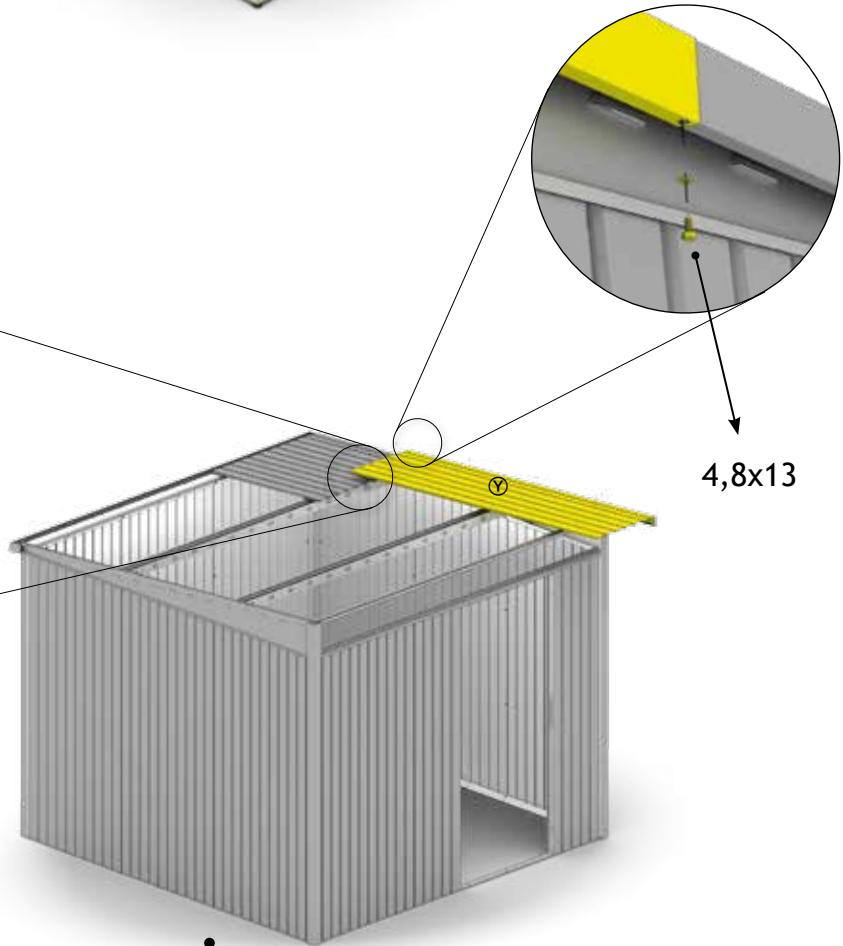
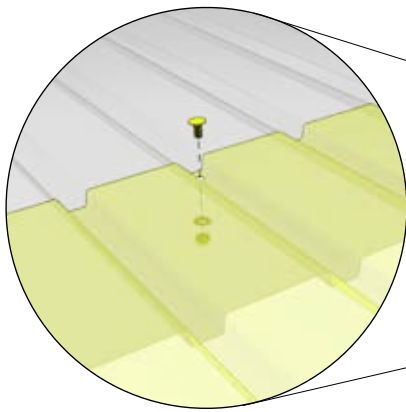

3.

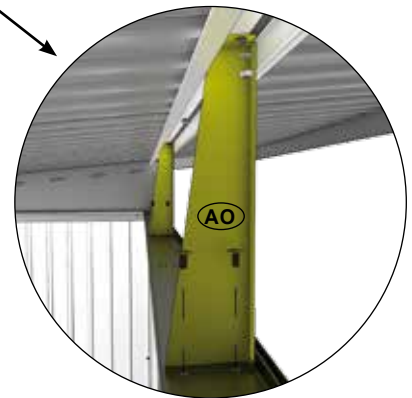
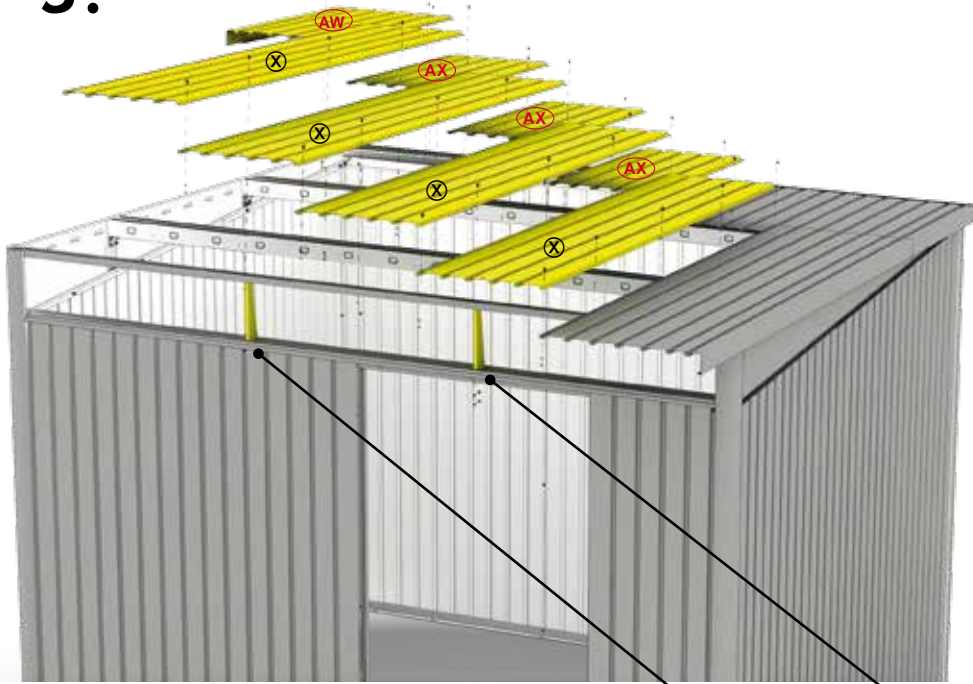
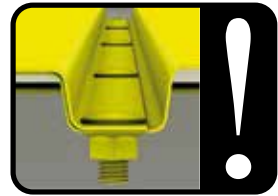

4.



4,8x13

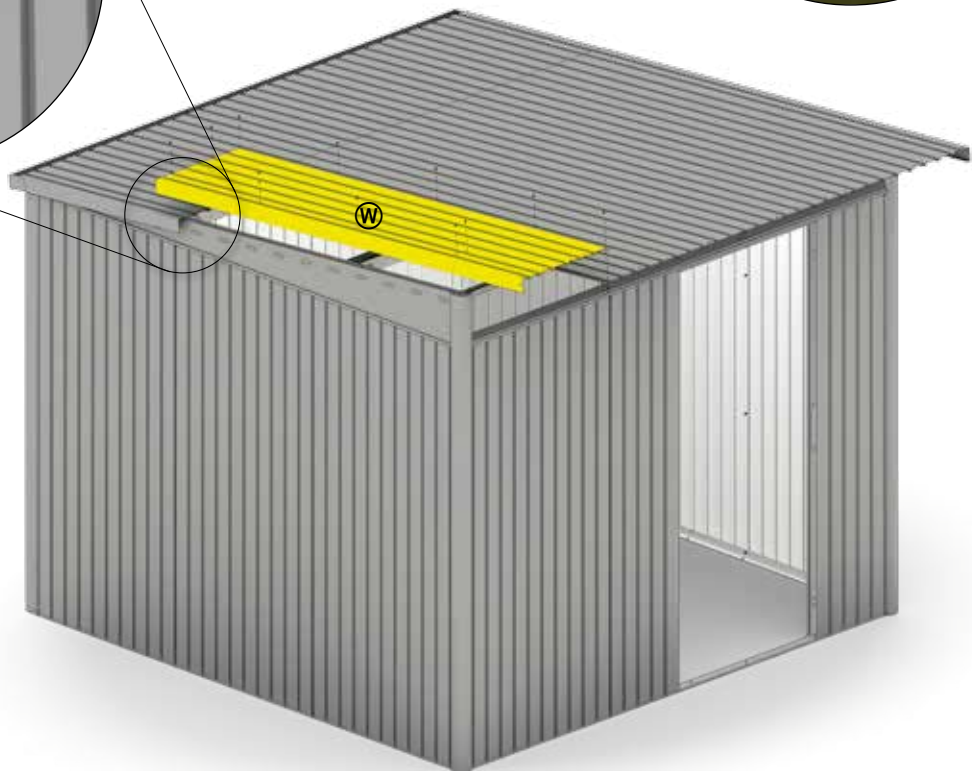

12.

	M: 1x L: 1x	M5 x 10 	M: 4x L: 4x
--	----------------	--	----------------

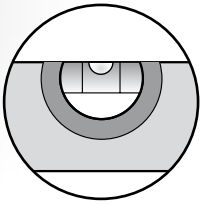
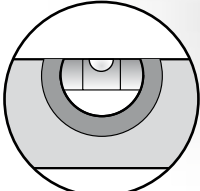
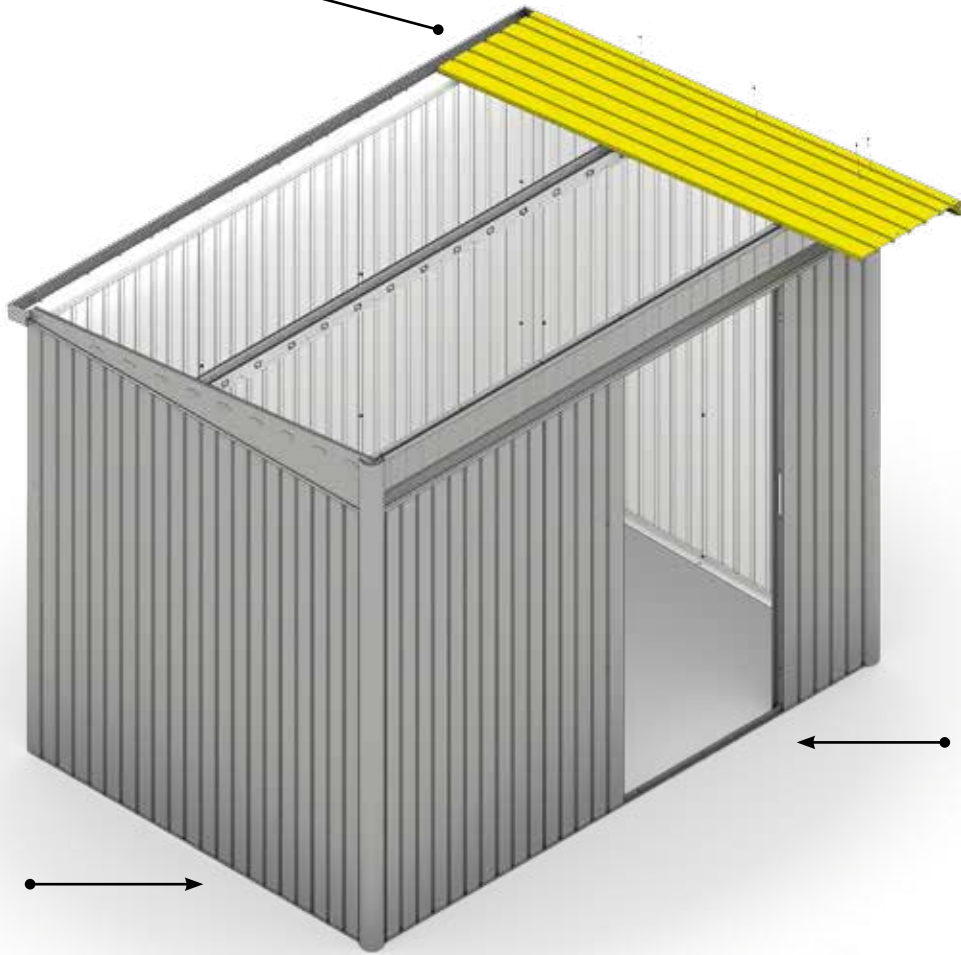
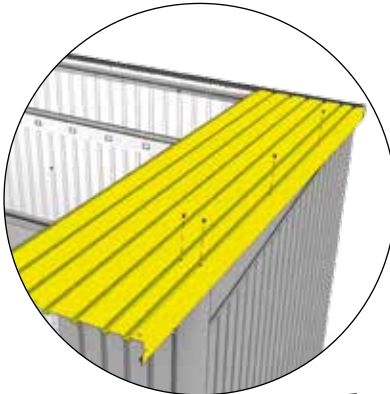

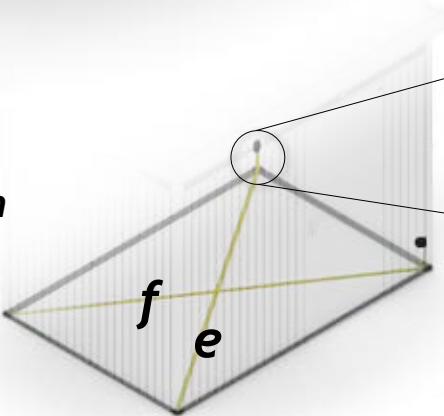

Rechtwinkelig einrichten

- ⒸB rectangular adjusted
- ⒸR ajuster en forme rectangulaire
- ⒸNL rechthoekig instellen
- ⒸES ajustar en forma rectangular
- ⒸIT mettere in squadra
- ⒸDK indstil vinkelret

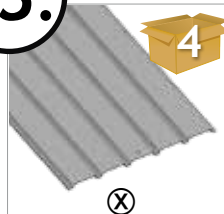
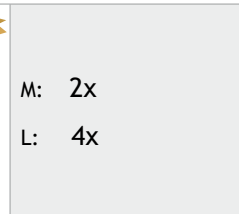

e = f

13.

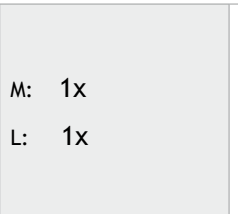
 <p>M: 2x L: 4x</p> <p>(X)</p>	<p>M: 1x L: 1x</p>	 <p>M: 1x L: 1x</p> <p>(W)</p>	<p>M5 x 10</p>  <p>(D2)</p>	<p>M: 16x L: 30x</p>
 <p>L: 2x</p> <p>(AO)</p>				

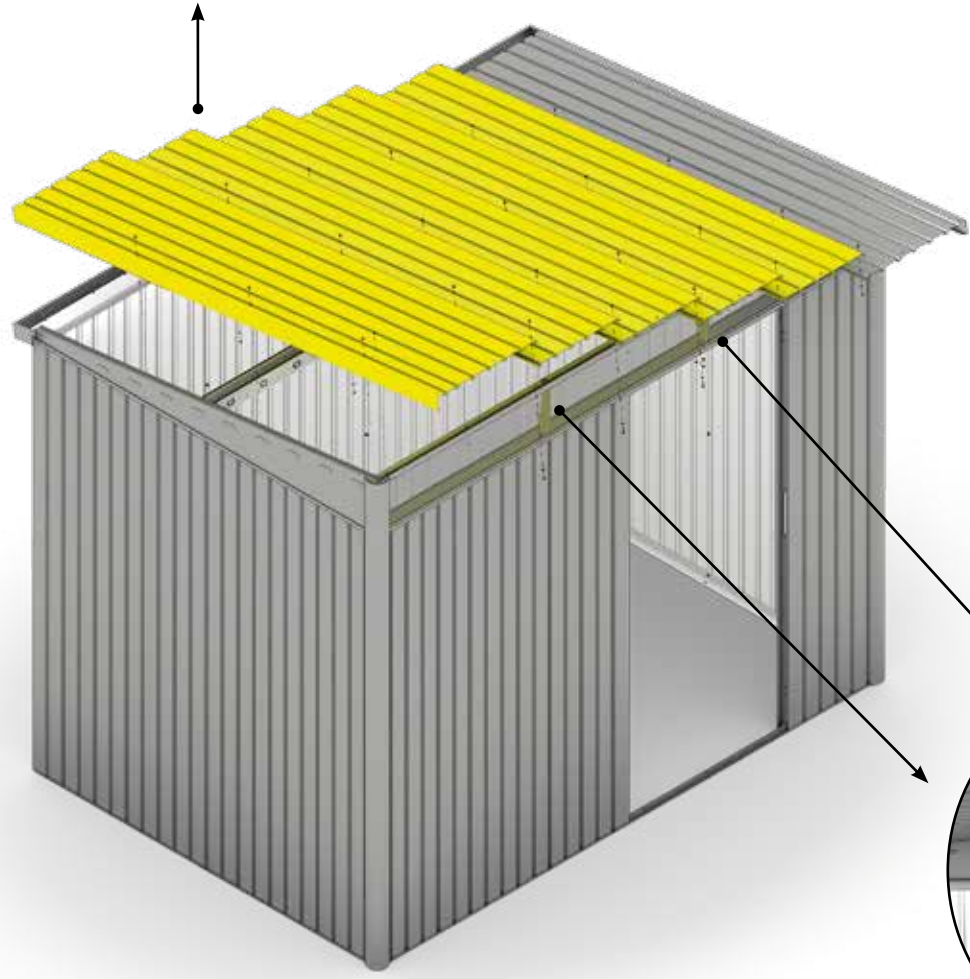
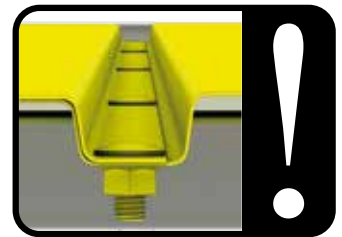
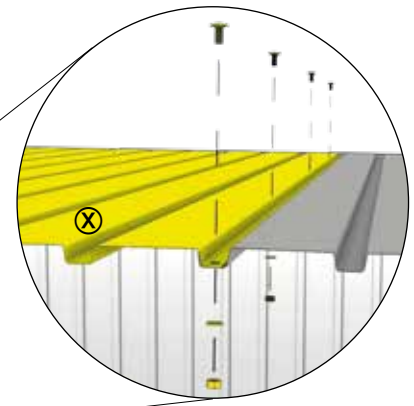
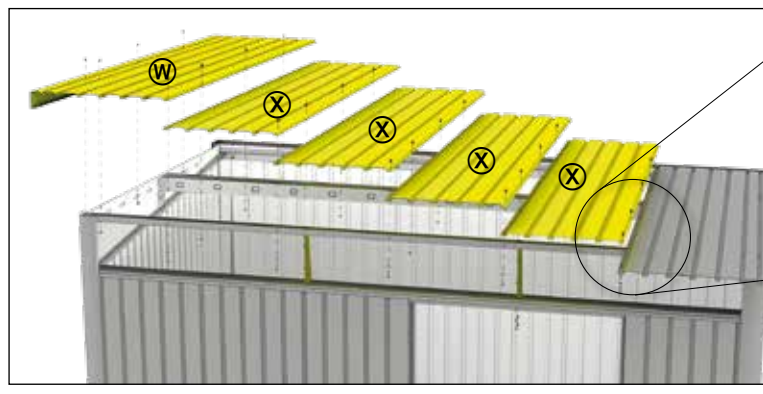

14.

4,8 x 13



D2

M: 11x
L: 15x
XL: 15x

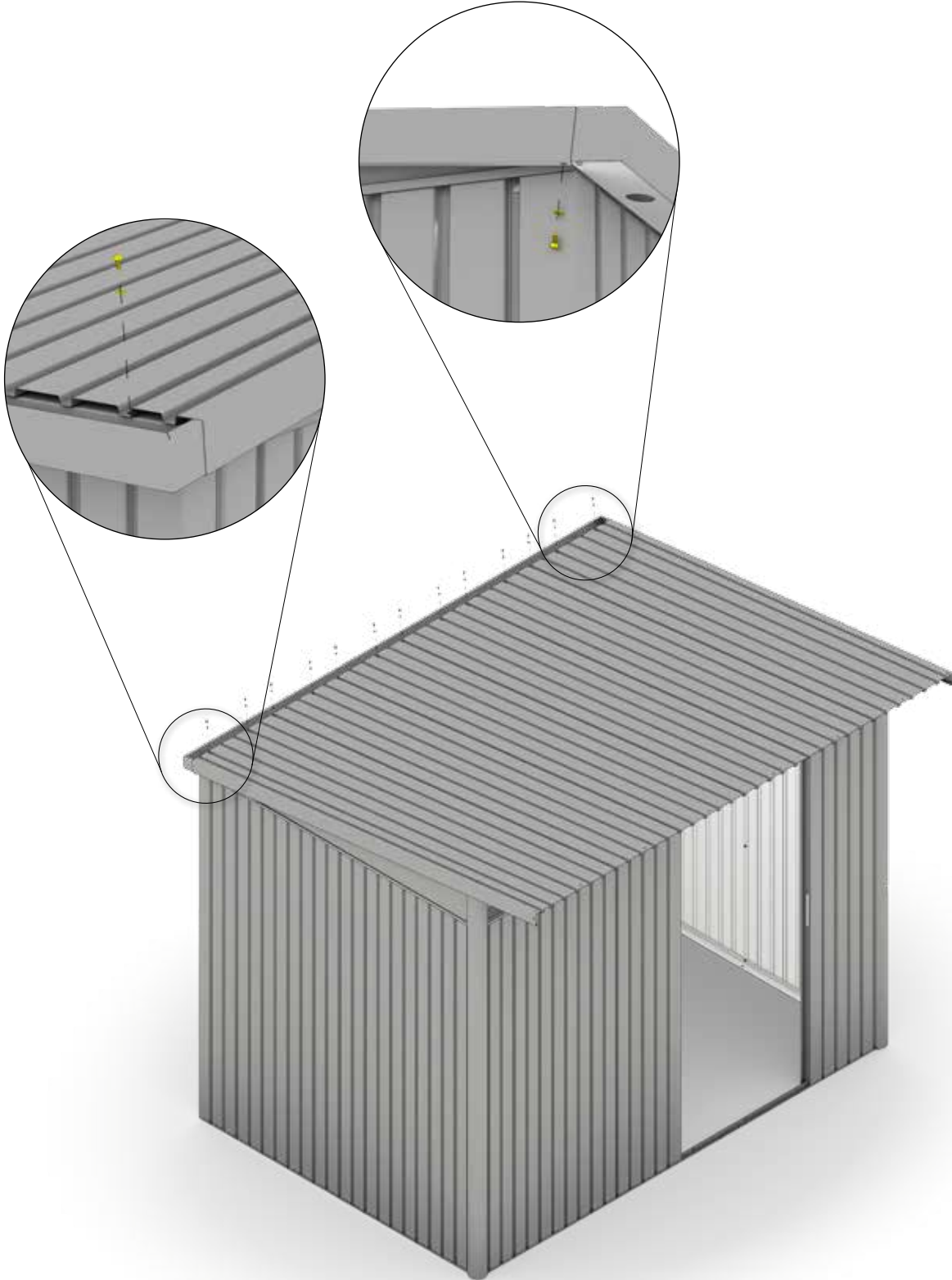

15.

4

M: 1X (1800mm)
L: 1X (2600mm)
XL: 1X (2600mm)

M5 x 10



M: 8x
L: 10x
XL: 10x

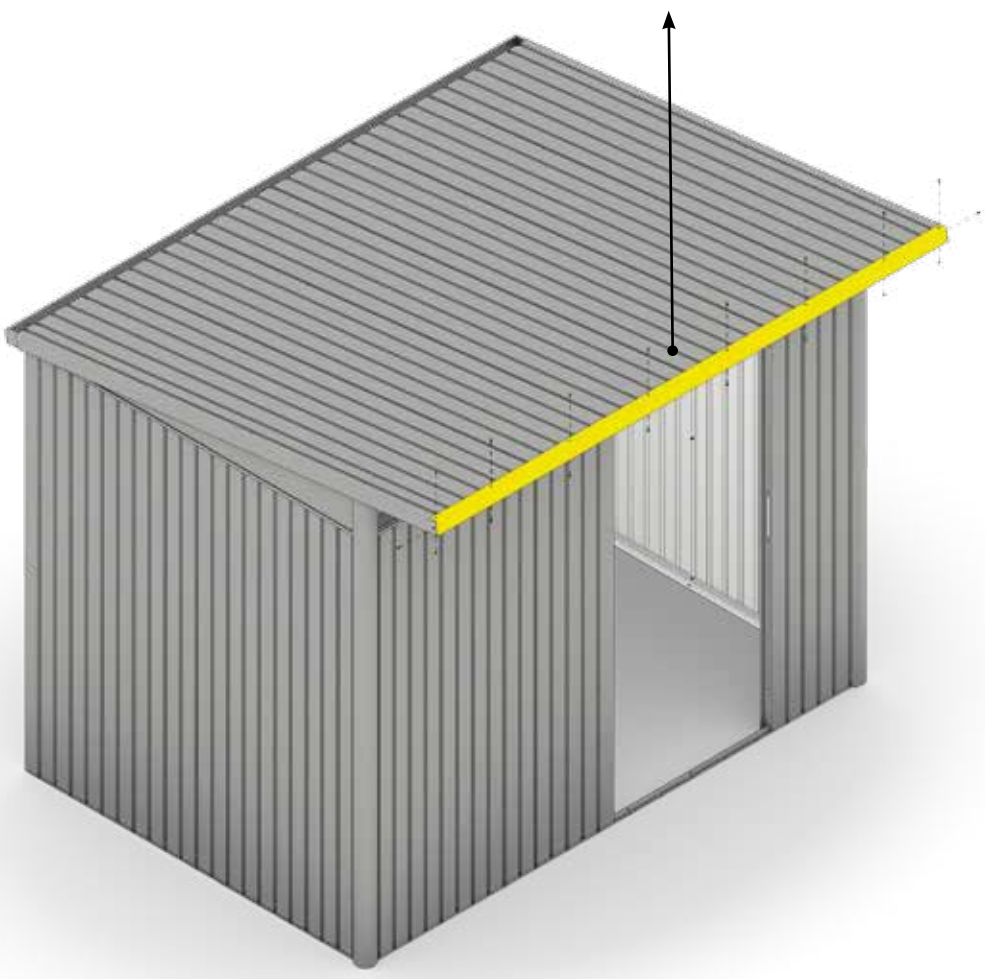
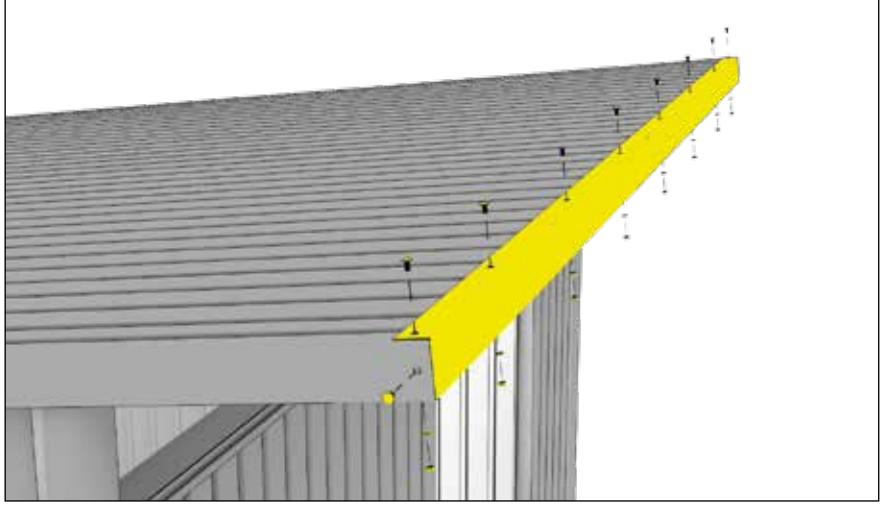
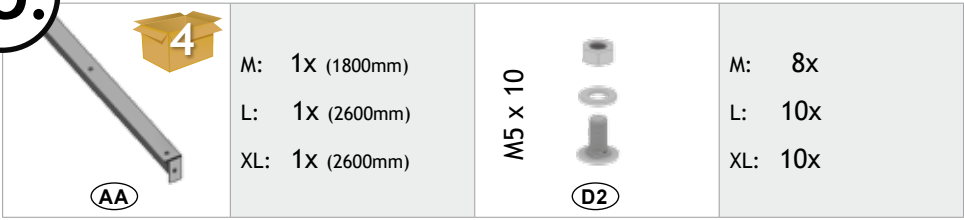

16.

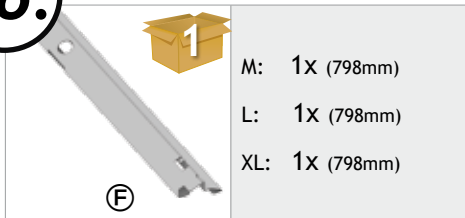

Doppeltür
 Double Door - Deuxième battant de porte -
 Tweede deurvleugel - Secondo battente -
 puerta doble - Dobbeltjør

L: 1X (1596mm)
XL: 1X (1596mm)

Bei Verwendung der Bodenschwellen-Rampe überspringen Sie diesen Schritt!

- ⒸGB If you use the floor ramp (optional accessory), please skip this step!
- ⒸFR Si vous utilisez le seuil de porte (accessoire) veuillez passer les étape!
- ⒸNL Bij toepassing van de oprijplaat (toebehoren) overslaan stap!
- ⒸES Si utiliza rampa de acceso (accesorio opcional) omite este paso en el montaje
- ⒸIT Se usi la rampa di accesso (accessorio opzionale), puoi saltare questo passaggio
- ⒸDK Spring dette skridt over, hvis du bruger gulvrampe!

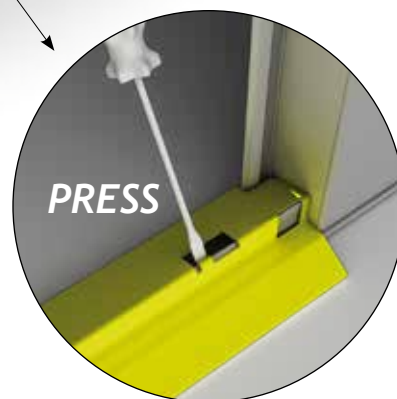
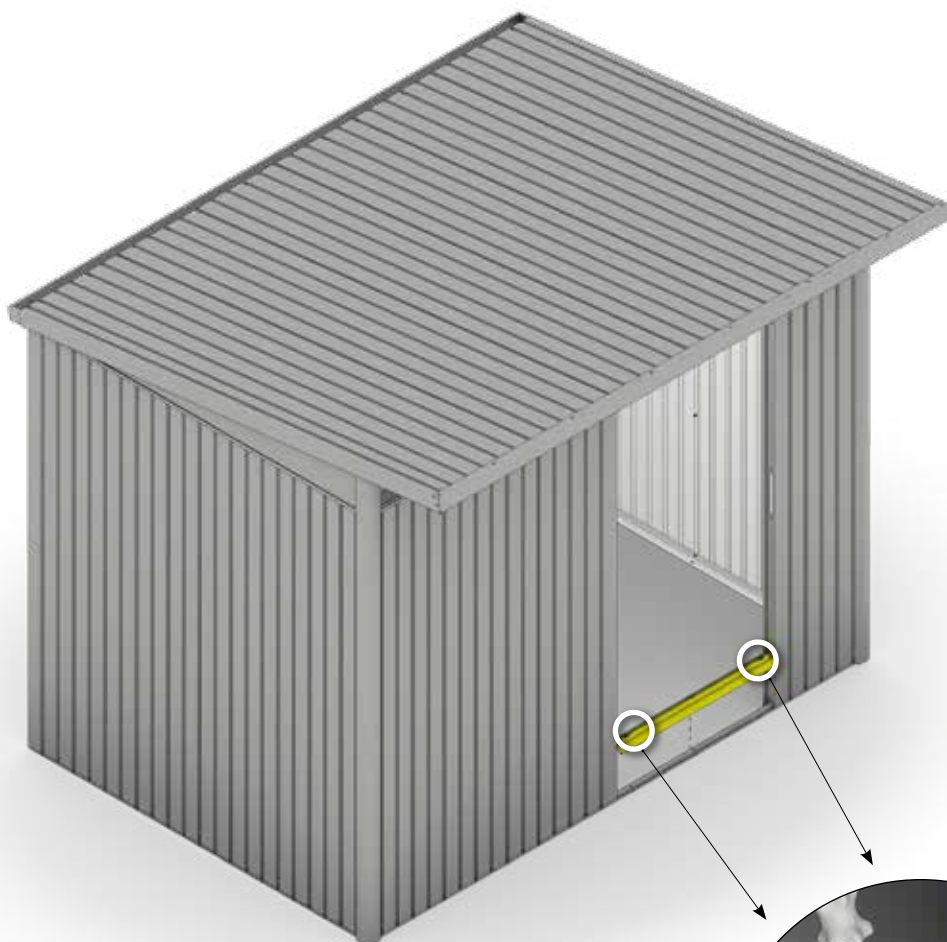



Bodenrahmen

Floor Frame - Cadre de sol - Bodemframe - Marco de suelo - Telaio perimetrale - Bundramme



ZD

M: 1x
L: 1x
XL: 1x

6,3 x 22



ZF

M: 1x
L: 1x
XL: 1x

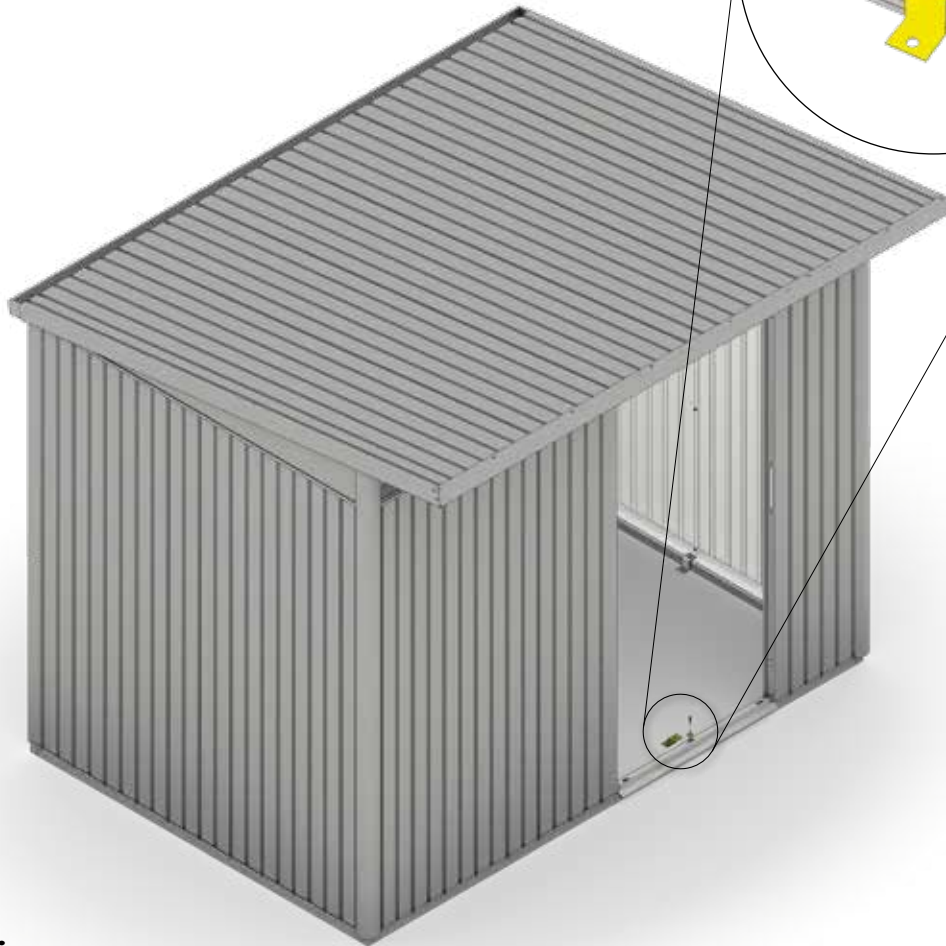
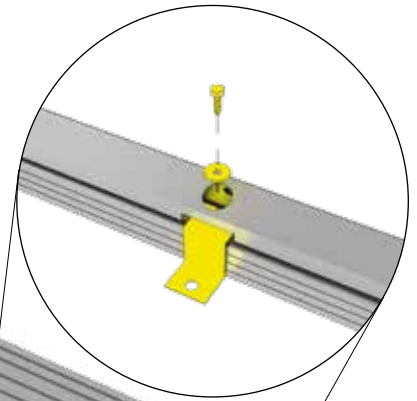

Doppeltür

Double Door - Deuxième battant de porte - Tweede deurvleugel - Secondo battente - puerta doble - Dobbeldør



ZD

L: 2x
XL: 2x

6,3 x 22



ZF

L: 2x
XL: 2x



17.

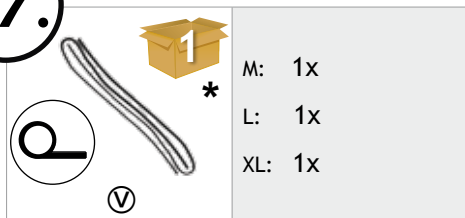

***Teil entfällt bei der Doppeltür**



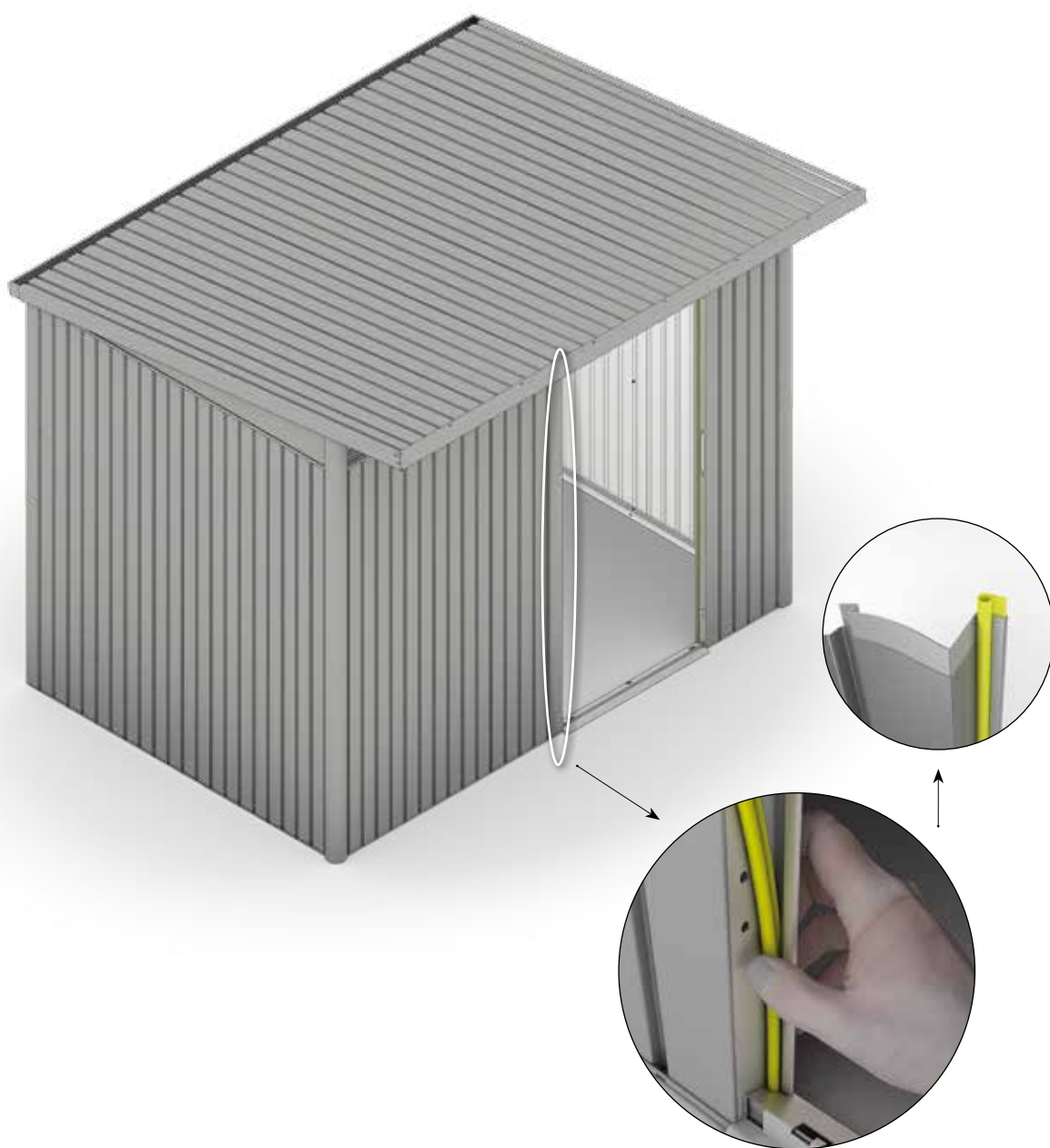

- Part not required when double doors are fitted
- La pièce est supprimée pour la double portes.
- Deel vervalt bij de dubbele deur
- Pieza no es necesaria en caso de puerta doble
- Pezzo non può essere utilizzato per la variante porta a due battenti
- Del ikke nødvendig med dobbeltdør







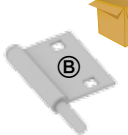

Doppeltür

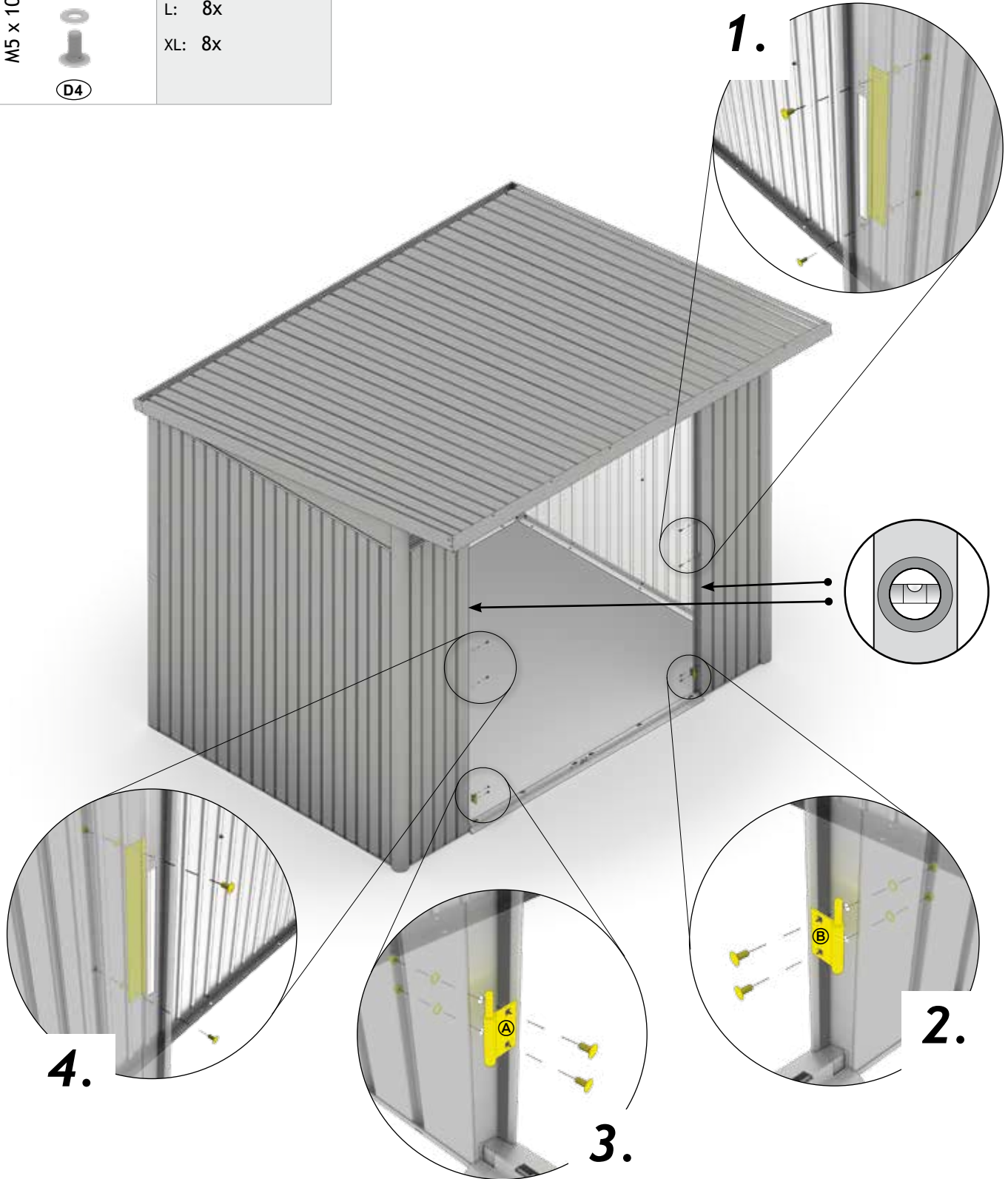
Double Door - Deuxième battant de porte - Tweede deurvleugel - Secondo battente - puerta doble - Dobbeldør

 <p>①</p>	<p>L: 2x XL: 2x</p>	 <p>Ⓐ</p> <p>ⓓ4</p>	<p>L: 1x XL: 1x</p>	 <p>Ⓑ</p> <p>ⓓ4</p>	<p>L: 1x XL: 1x</p>
<p>M5 x 10</p>  <p>ⓓ4</p>	<p>L: 8x XL: 8x</p>				

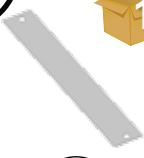

18.

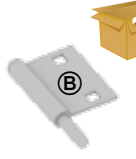
 <p>I</p>	<p>M: 1x L: 1x XL: 1x</p>	 <p>N</p>	<p>M: 1x L: 1x XL: 1x</p>	<p>M5 x 12</p>  <p>D4</p>	<p>M: 2x L: 2x XL: 2x</p>
<p>M5 x 10</p>  <p>D4</p>	<p>M: 8x L: 8x XL: 8x</p>	 <p>B</p> <p>D4</p>	<p>M: 1x L: 1x XL: 1x</p>		

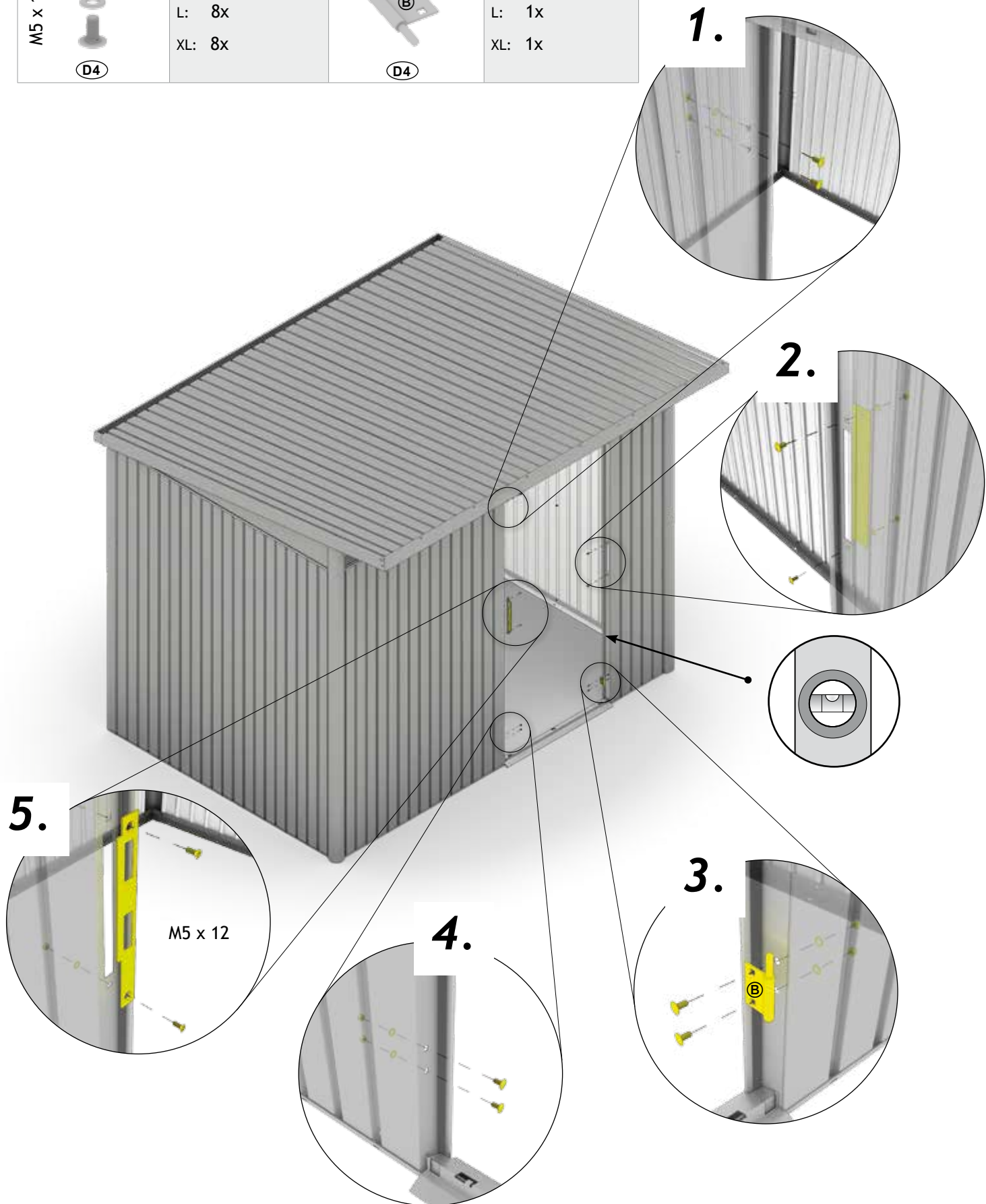



Doppeltür

Double Door - Deuxième battant de porte - Tweede deurvleugel - Secondo battente - puerta doble - Dobbeldør

	<p>L: 1x XL: 1x</p>		<p>L: 1x XL: 1x</p>	<p>M5 x 10</p>	<p>L: 4x XL: 4x</p>
	<p>L: 1x XL: 1x</p>		<p>L: 1x XL: 1x</p>		

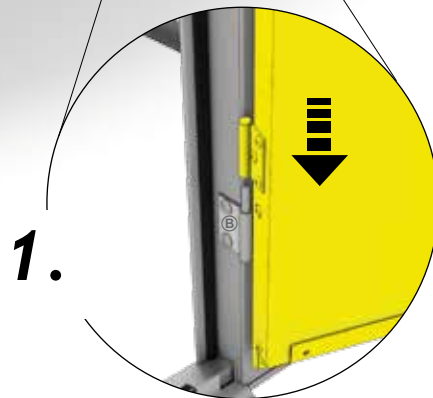
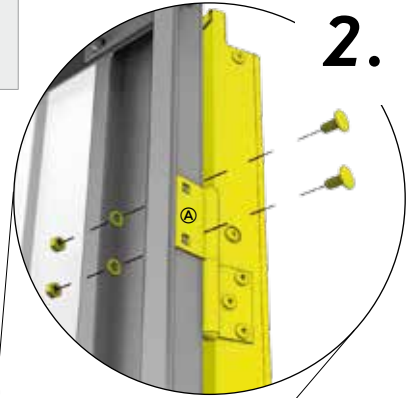
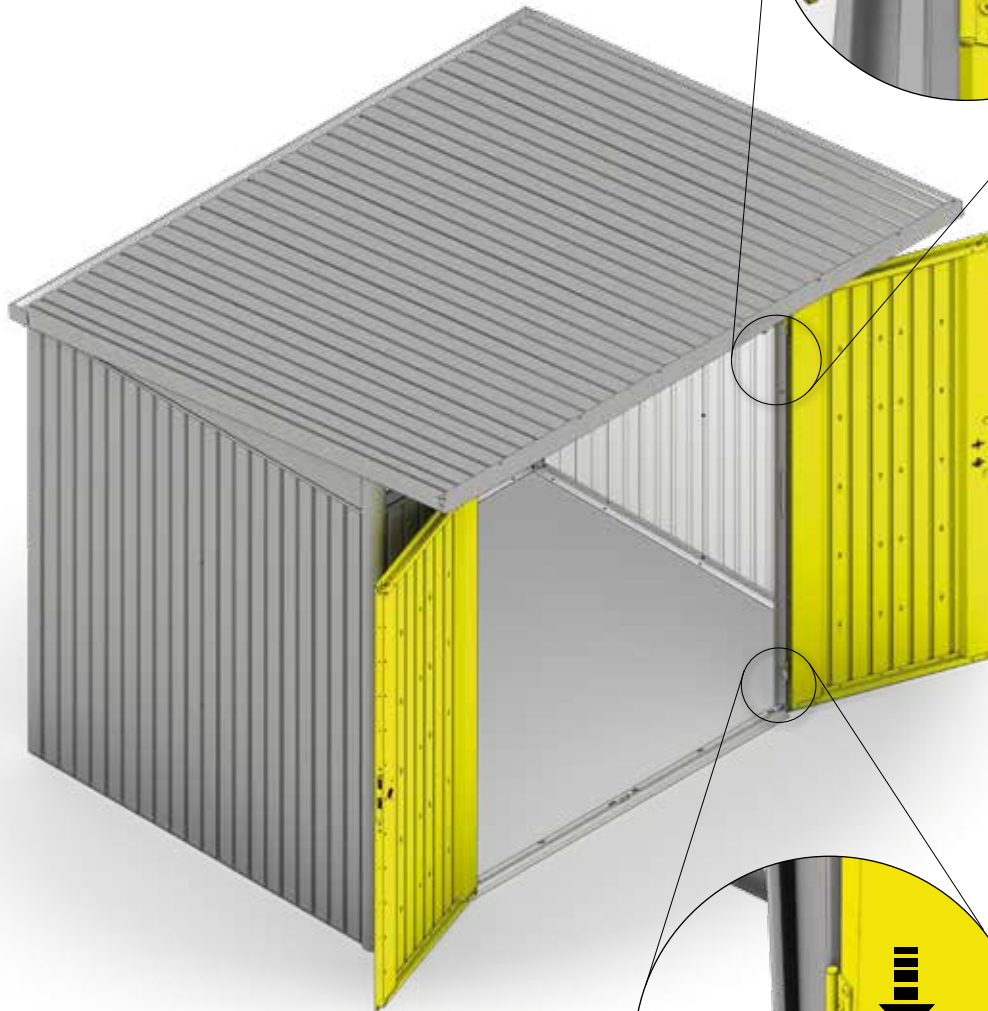

19.

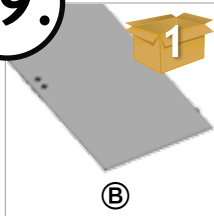

M: 1x
L: 1x
XL: 1x

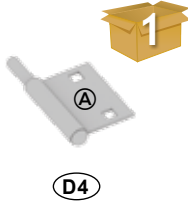

M: 1x
L: 1x
XL: 1x



M: 2x
L: 2x
XL: 2x

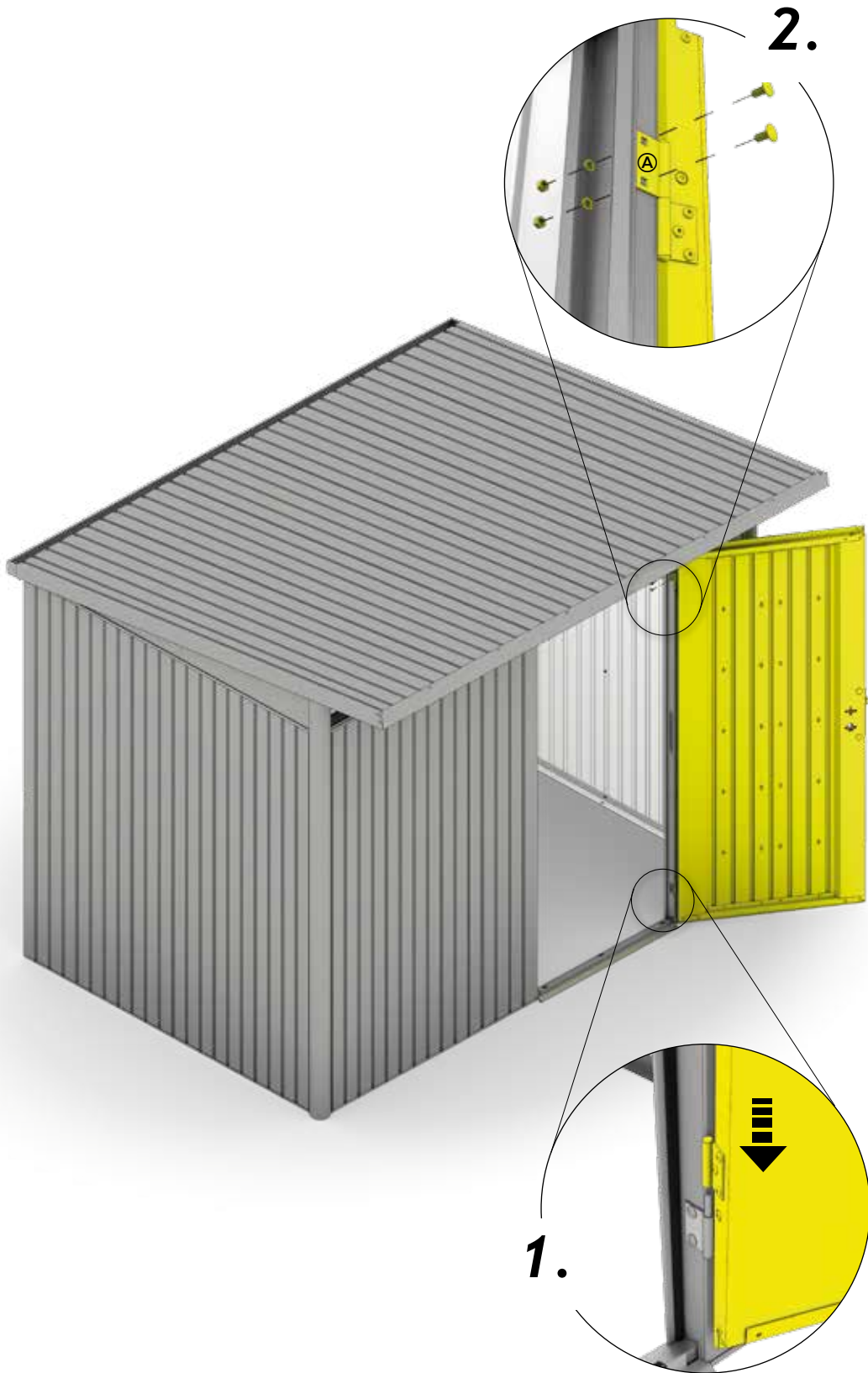

2.

1.

20.

	M: 1x
	L: 1x
	XL: 1x
D3	

Reserveschlüssel für Nachfertigung separat aufbewahren!

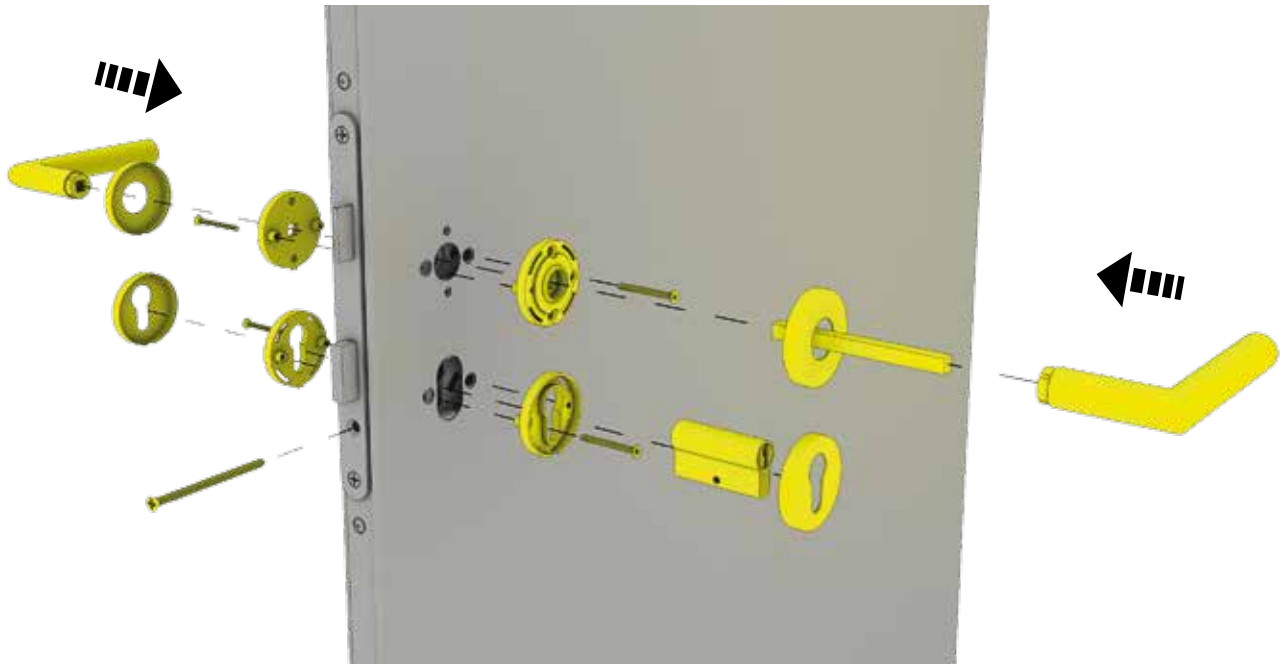

- (GB)** Please keep a spare key separately in case you need to make copy
- (FR)** Veuillez conserver vos clés de réserve séparément.
- (NL)** Reservesleutel a.u.b. apart bewaren. Dit i.v.m. eventuele nabestellingen!
- (ES)** Guarde una llave de repuesto separadamente por si tiene que encargar una copia.
- (IT)** Conservare la chiave di riserva in luogo sicuro per un' eventuale post-fabbricazione!
- (DK)** Gem reservenøglen separat, til hvis du skal lave en kopi!



optionales Zubehör - Accessories - Accessoires - Toebehoor - Accessori - Accesorios - Ekstraudstyr

Doppeltür



Double Door - Deuxième battant de porte - Tweede deurvleugel - Secondo battente - puerta doble - Dobbeldør

	1x	4,8 x 13		L: 2x
	1x			XL: 2x
K		D4		





optionales Zubehör - Accessories - Accessoires - Toebehoor - Accessori - Accesorios - Ekstraudstyr

21.

 <p>M: 1x L: 1x XL: 1x</p> <p>ⓐ</p>	<p>4,8 x 13</p>  <p>ⓓ2</p>	<p>M: 5x L: 5x XL: 5x</p>	 <p>ⓓ4</p>	<p>M: 1x L: 1x XL: 1x</p>
--	---	-----------------------------------	---	-----------------------------------

Doppeltür

Double Door - Deuxième battant de porte - Tweede deurvleugel - Secondo battente - puerta doble - Dobbeltjør

 <p>ⓐ</p>	<p>L: 2x XL: 2x</p>	<p>4,8 x 13</p>  <p>ⓓ4</p>	<p>L: 10x XL: 10x</p>
 <p>ⓓ4</p>	<p>L: 2x XL: 2x</p>		

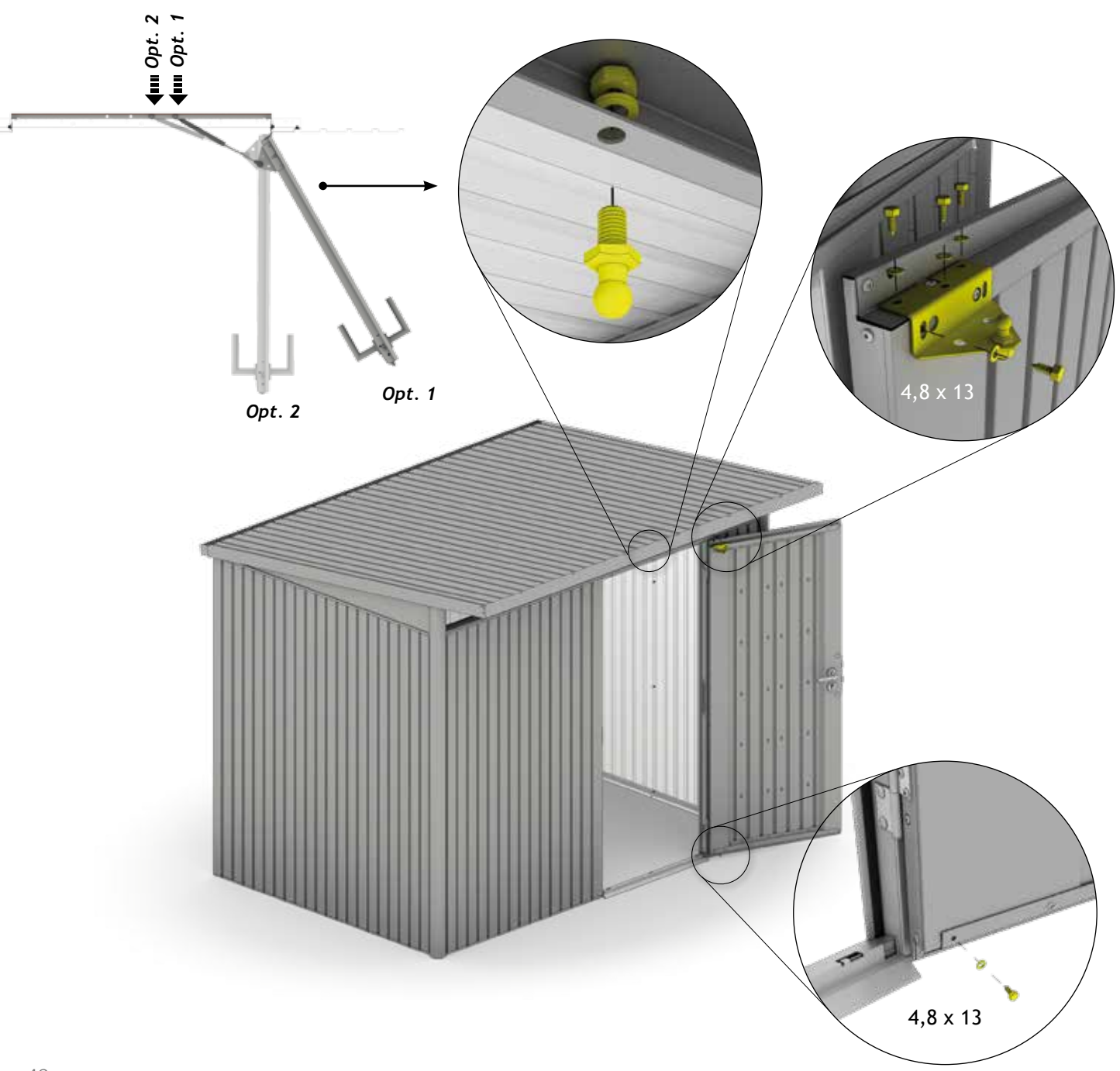

22.

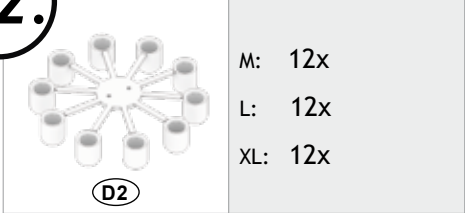

Rechtwinkelig einrichten

- Ⓒ rectangular adjusted
- Ⓕ ajuster en forme rectangulaire
- Ⓖ rechthoekig instellen
- Ⓔ ajustar en forma rectangular
- Ⓜ mettere in forma rettangolare
- Ⓓ indstil vinkelret

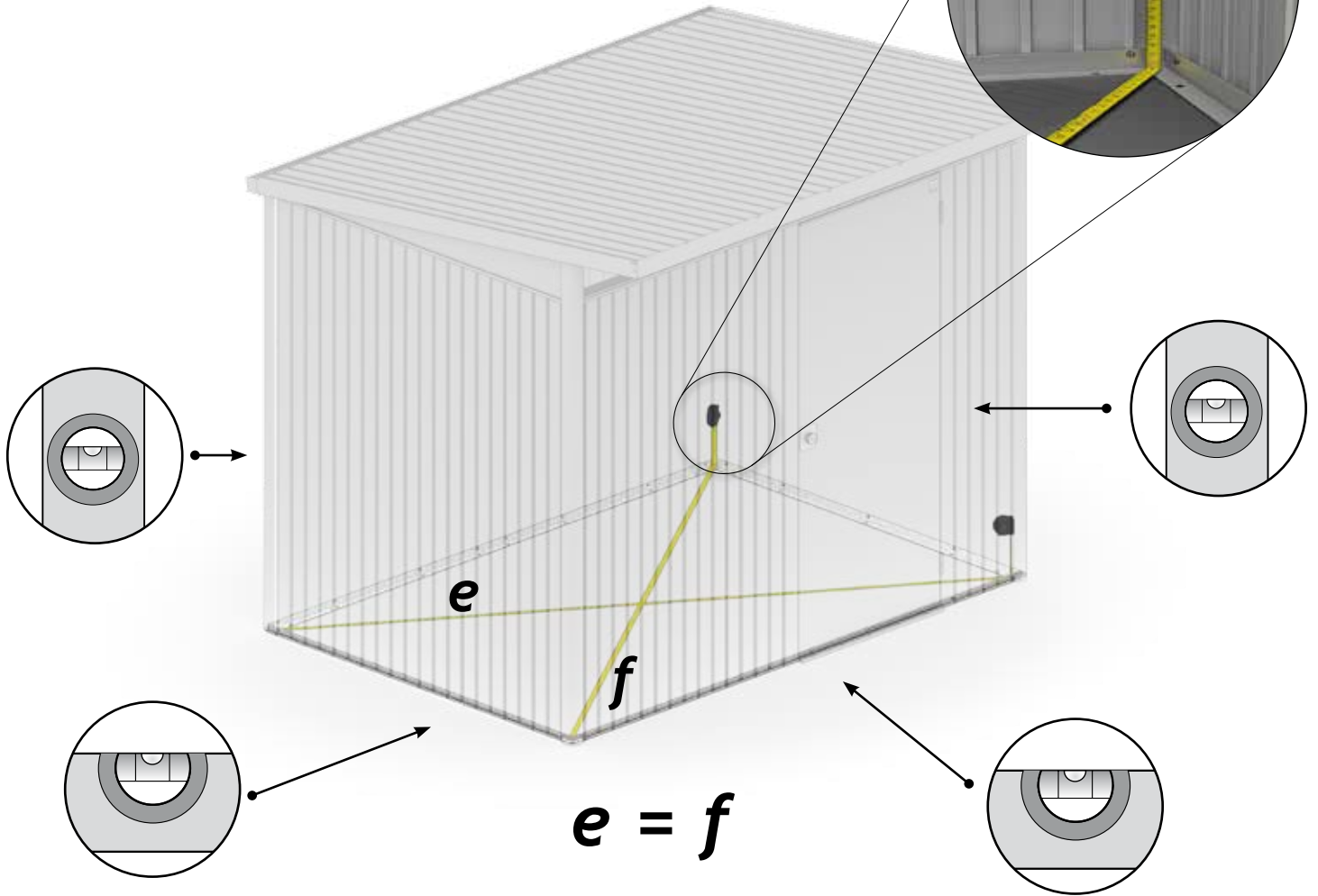

Ziehen Sie jetzt alle Schraubverbindungen fest an!

Tighten now all nuts and connections securely! - Serrez maintenant les vis à fond! - Draai nu alle schroeven vast! - Ahora puede apretar y fijar todos los tornillos y tuercas - Adesso serrare a fondo tutti i dadi - Fastspænd nu alle bolt-/skruerforbindelser!

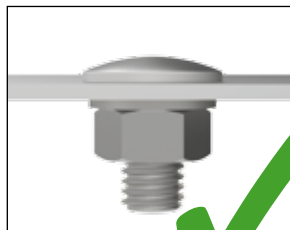
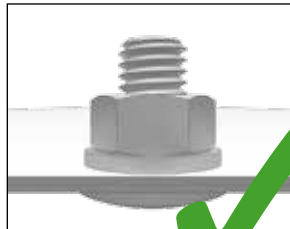

23.

Tür einrichten

- Ⓒ align the door
- Ⓕ ajuster la porte
- Ⓖ deur afstellen
- Ⓔ ajuste la puerta
- Ⓜ aggiustare la porta
- Ⓡ justering af dør

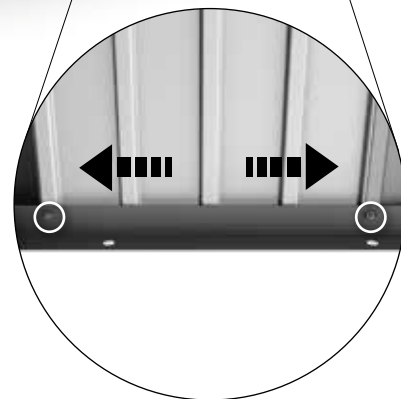
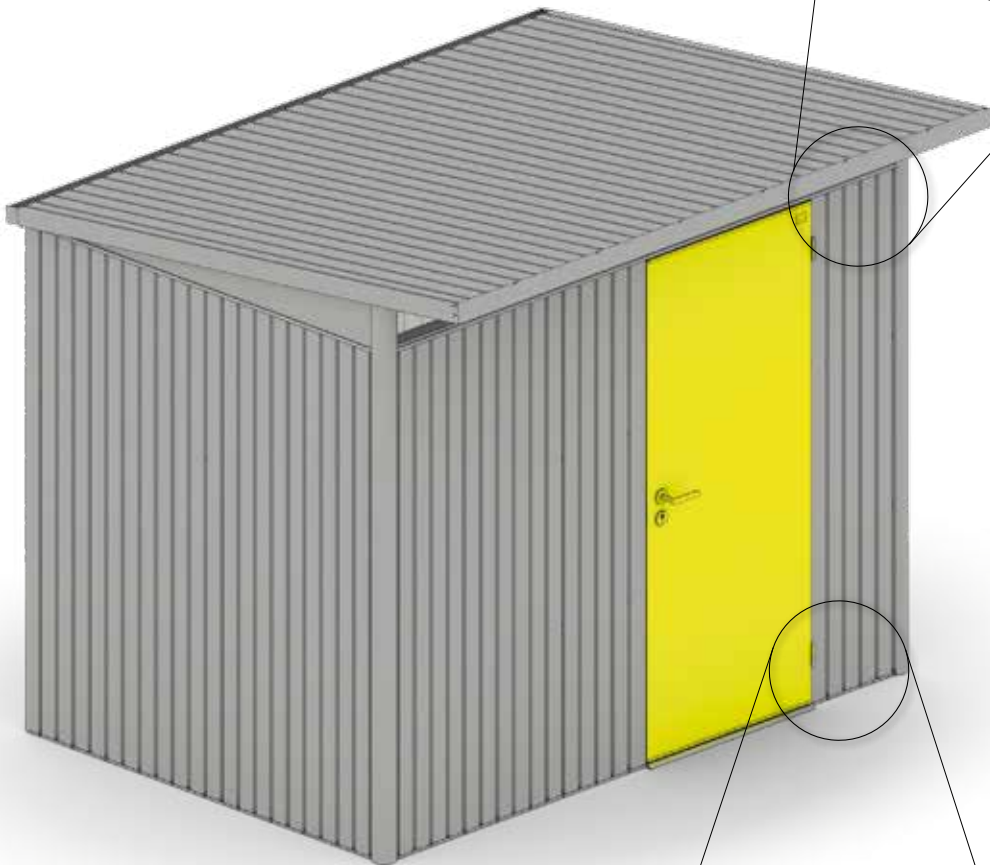
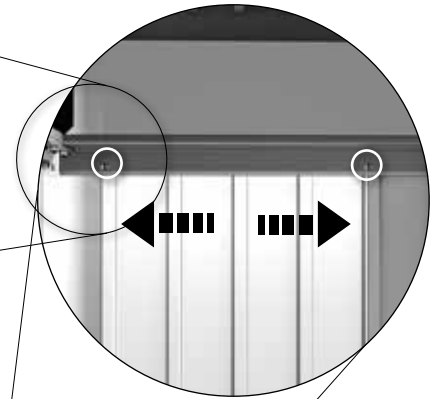
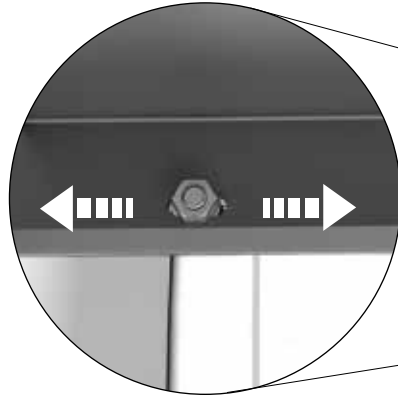

24.

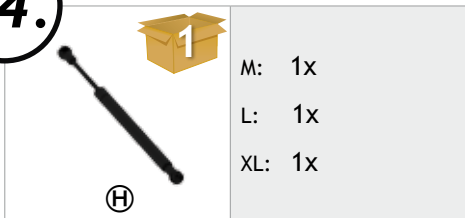

Doppeltür

Double Door - Deuxième battant de porte -
Tweede deurvleugel - Secondo battente -
puerta doble - Dobbeltjør

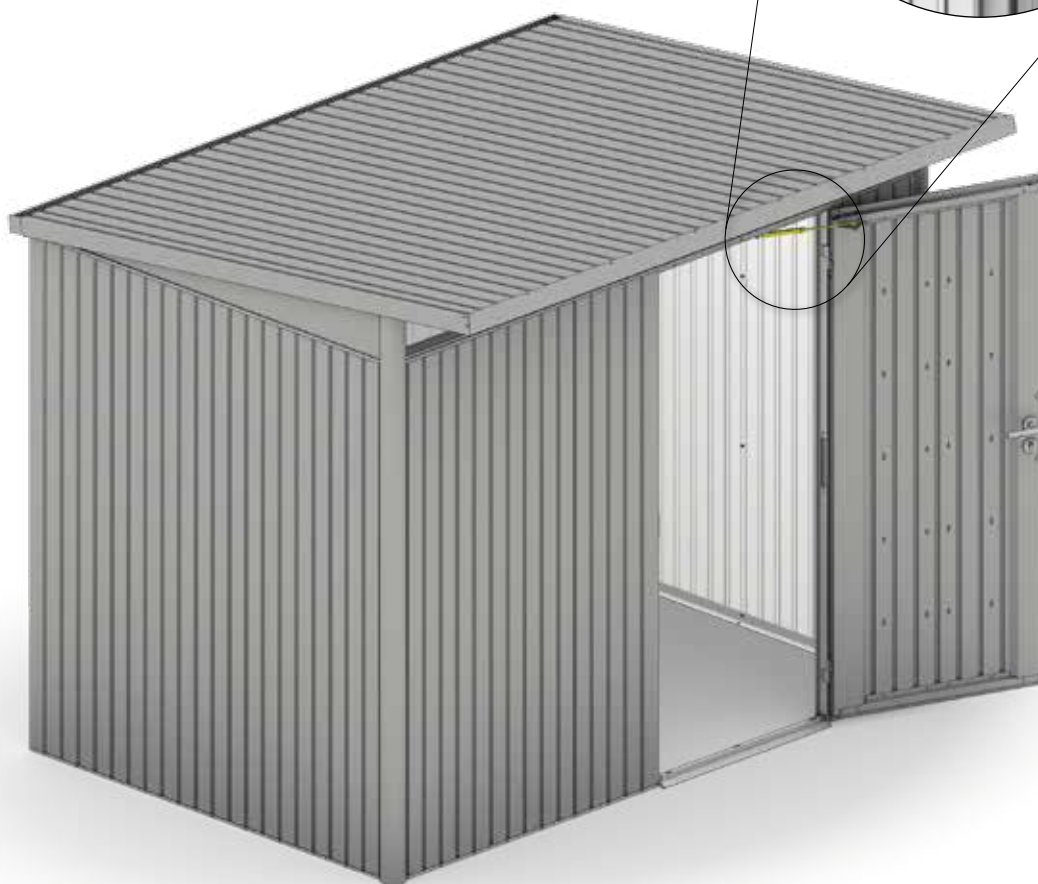
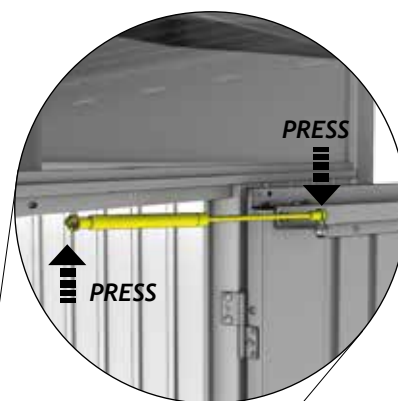



Bodenrahmen

Floor Frame - Cadre de sol - Bodemframe - Marco de suelo - Telaio perimetrale - Bundramme

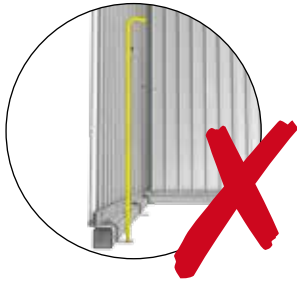
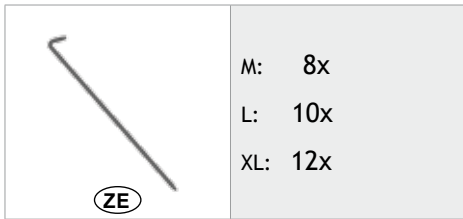

Variante 1 - (Seite 4), Proposal 1 - (page 4), Variant 1 - (page 4)

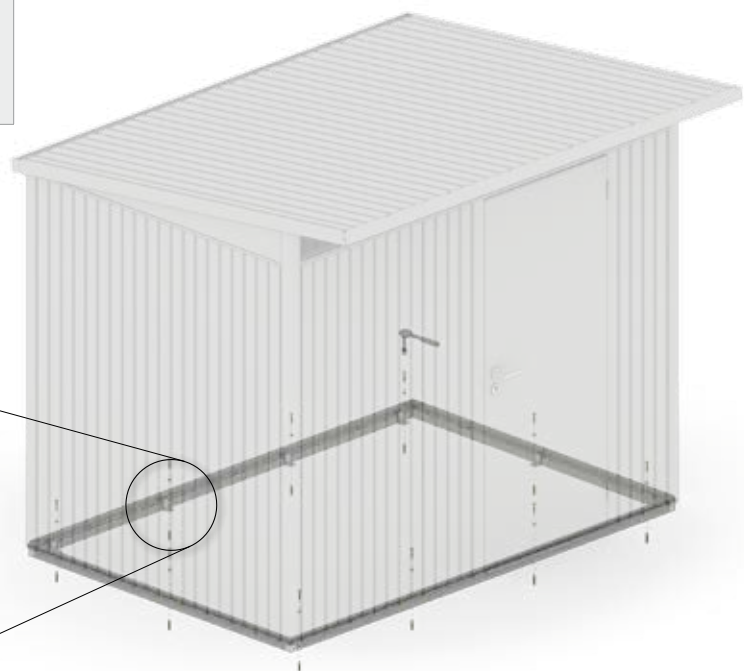
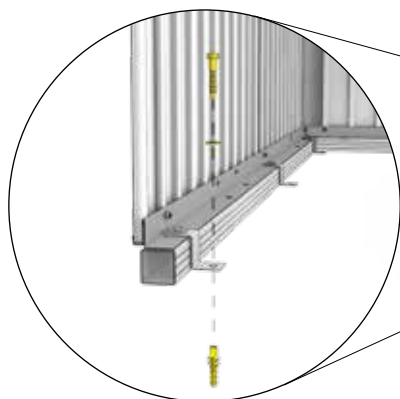
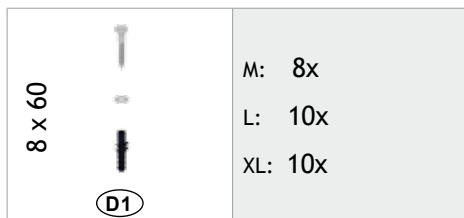

Variante 2 - (Seite 5), Proposal 2 - (page 5), Variant 2 - (page 5)



25.

8 x 60 D1		M: 8x
		L: 10x
		XL: 10x

Variante 3 - (Seite 5), Proposal 3 - (page 5), Variant 3 - (page 5)

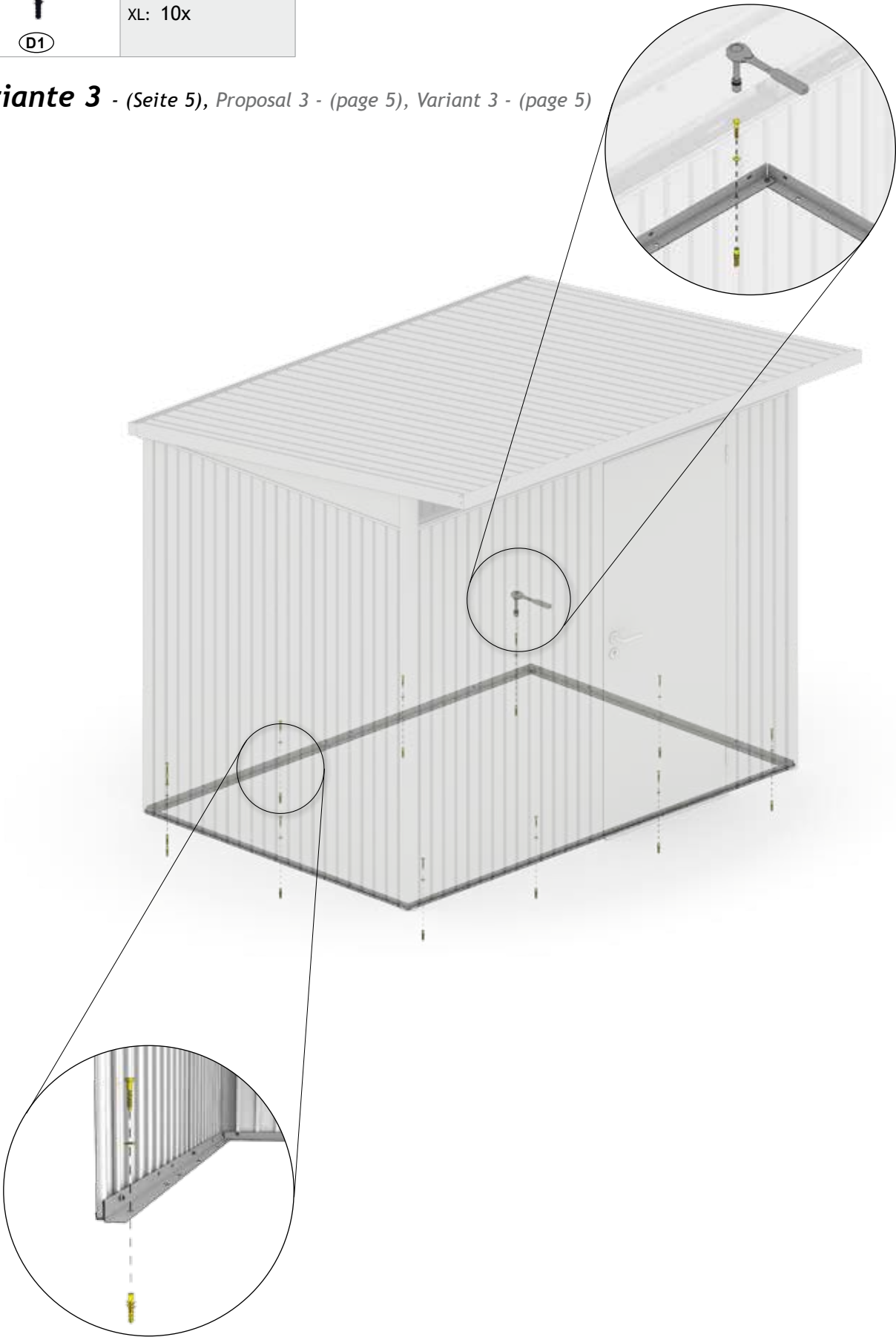

26.

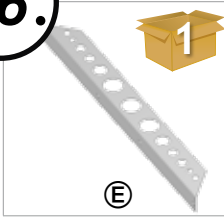
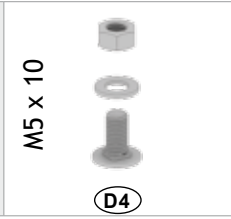
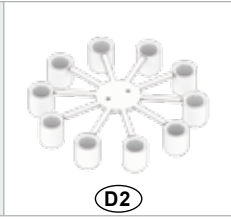
 <p>Ⓔ</p>	<p>M: 2x L: 2x XL: 2x</p>	<p>M5 x 10</p>  <p>Ⓓ4</p>	<p>M: 8x L: 8x XL: 8x</p>	 <p>Ⓓ2</p>	<p>1x</p>
---	-----------------------------------	--	-----------------------------------	---	-----------

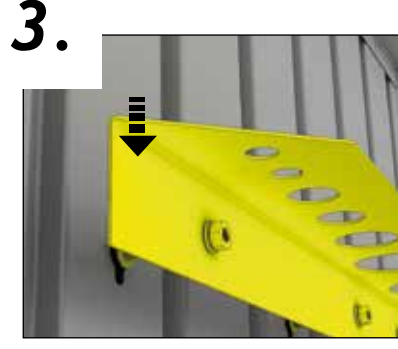
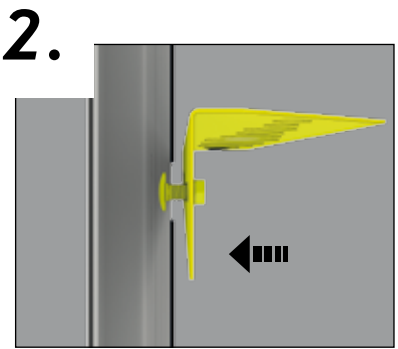
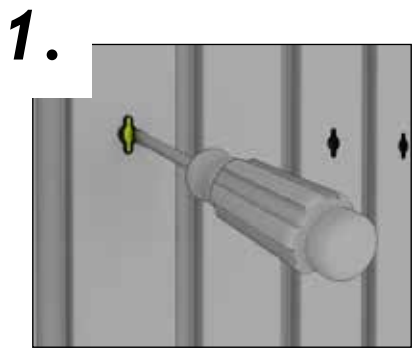

27.

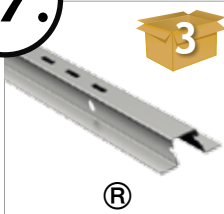

M: 2x
L: 2x
XL: 2x



M: 2x
L: 2x
XL: 2x



M: 4x
L: 4x
XL: 4x

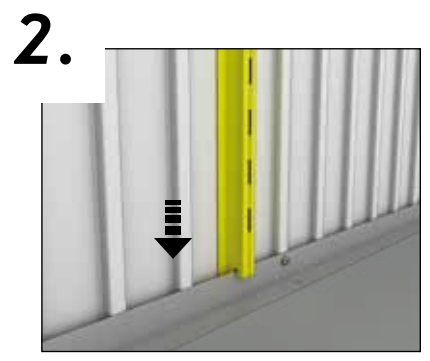
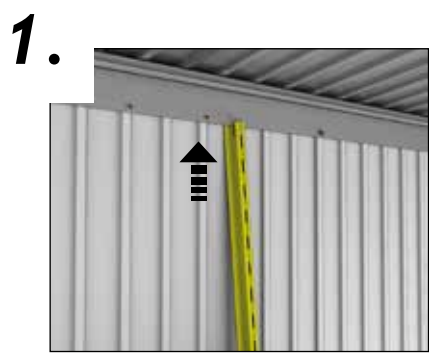

Option 1:

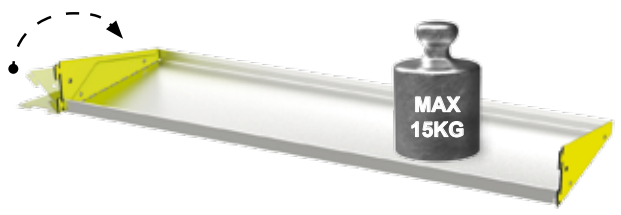

Option 2:

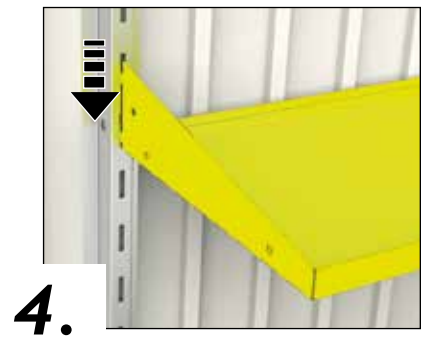
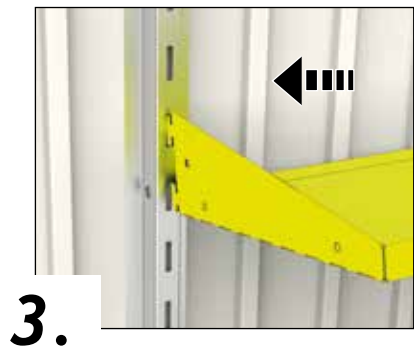
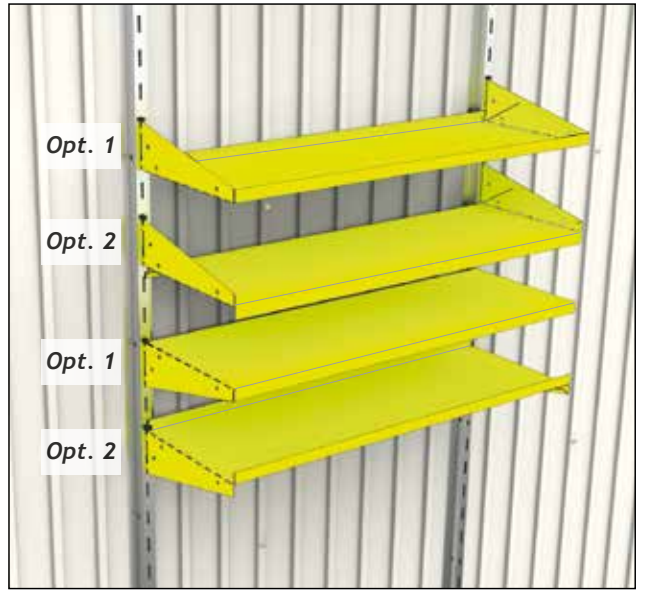

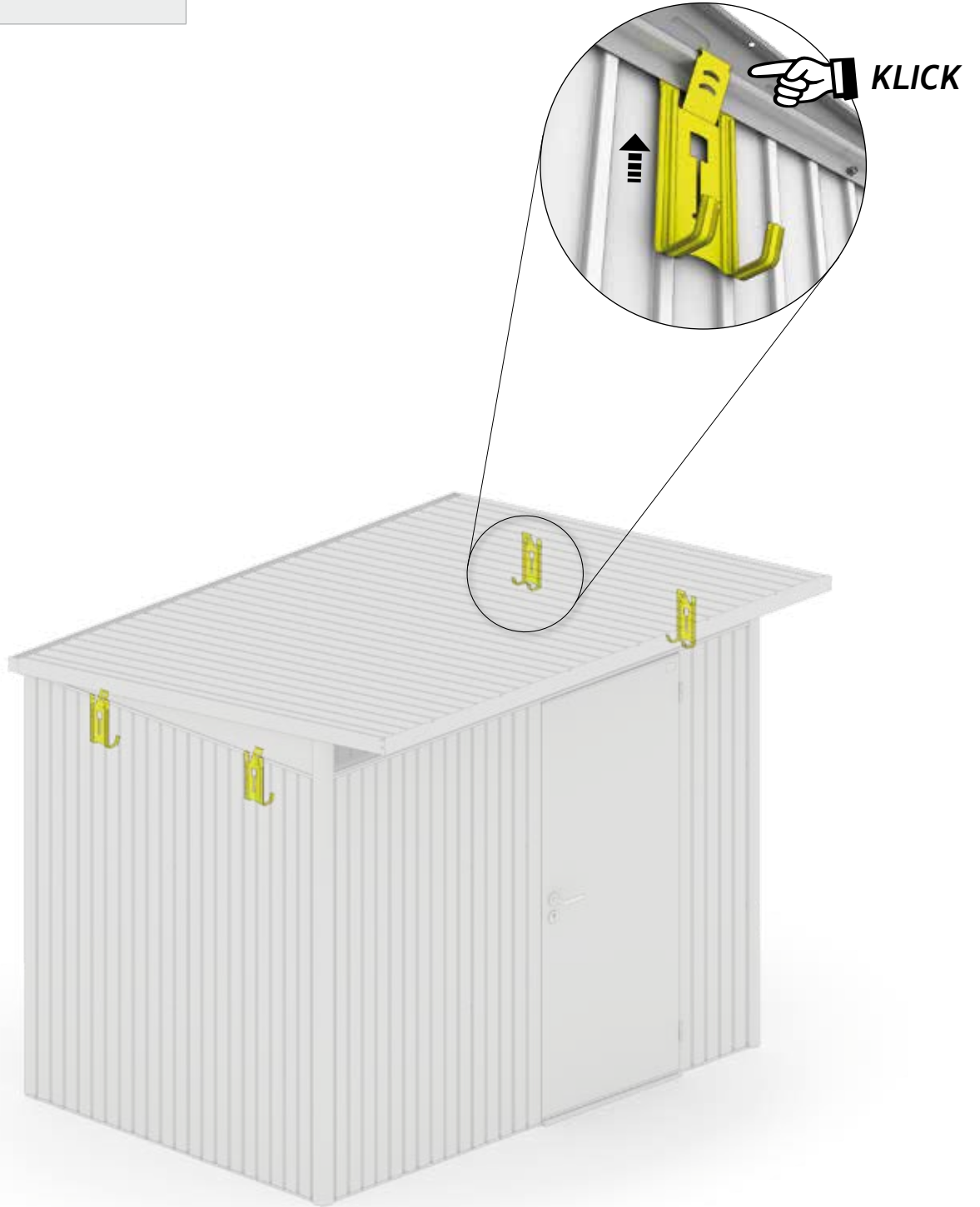
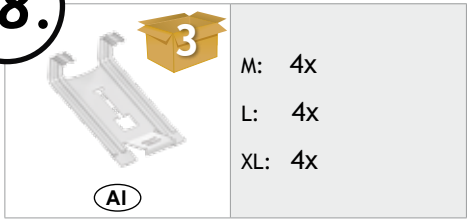

28.



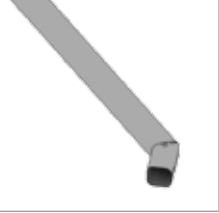

Regenfallrohr

Rain water downpipe - Descente d'eaux pluviales - Regenpijpsset - Set di tubi pluviali - Set de bajante - Tagnedløb

	<p>M: 2x L: 2x XL: 2x</p>	<p>M4 x 10</p> 	<p>M: 4x L: 4x XL: 4x</p>		<p>M: 2x L: 2x XL: 2x</p>
--	-----------------------------------	--	-----------------------------------	---	-----------------------------------

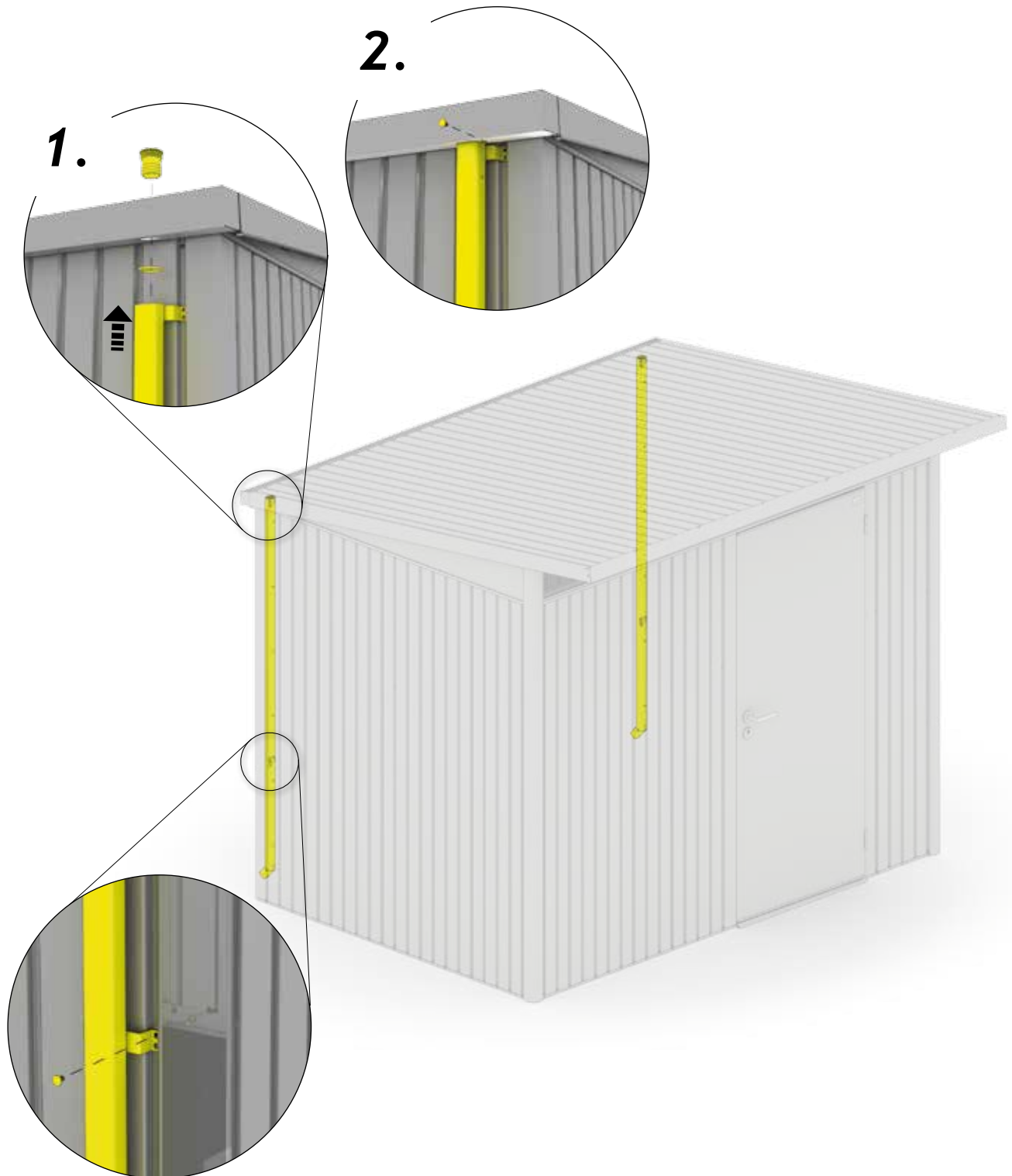

29.



M: 2x

L: 2x

XL: 2x

Variante 2

Maximal einen Auslauf als Überlaufschutz.

One outlet maximum for overflow protection.

Maximum un raccord par évacuation.

Maximaal één uitloopje tegen overlopen.

Como máximo un canalón como protección contra rebose.

Al massimo una grondaia come protezione di trabocco.

Variante 1

1.

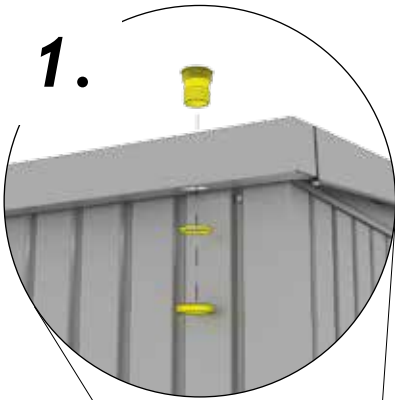

2.

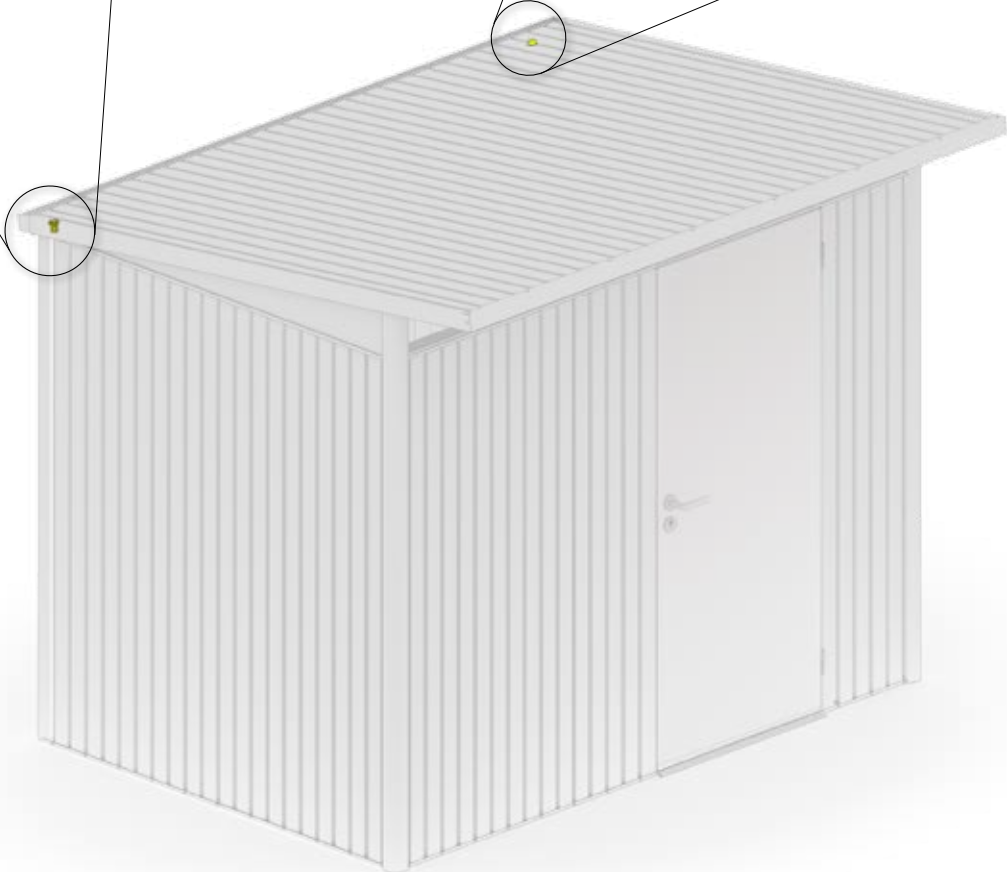
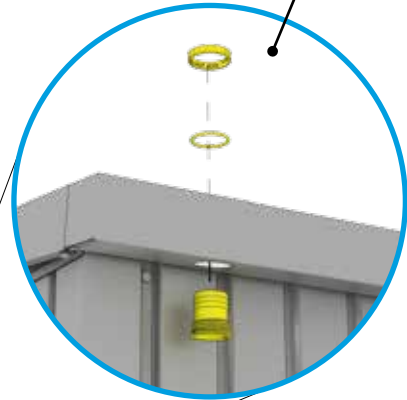
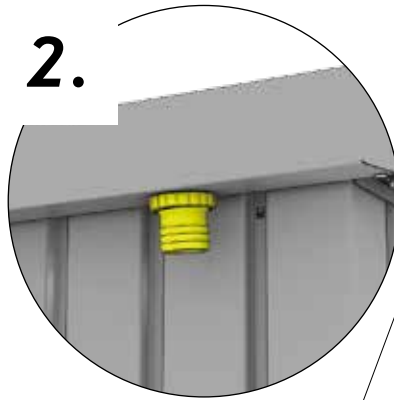

30.

M: 6X (1250 x 600mm)

L: 10X (1250 x 600mm)

XL: 15X (1250 x 600mm)

optionale Dachisolierung mit Isolierplatten (2cm) (nicht im Lieferumfang)

Ⓒ ROOF INSULATION - polystyrene panels (2cm), (not in scope of supply)

Ⓒ PRÉPARATION POUR L'ISOLATION DU TOIT - plaques de styrodur (2cm),
(Pas inclus dans la livraison)

Ⓒ VOORBEREID VOOR DAKISOLATIE - piepschuimplaten (2cm), (niet in leveringsomvang)

Ⓒ PREPARACIÓN PARA EL AISLAMIENTO DE LA CUBIERTA - poliestireno (2cm),
(No incluido en el volumen de entrega)

Ⓒ PREDISPOSIZIONE PER LA COIBENTAZIONE DEL TETTO - di pannelli in polistirolo (2cm),
(non forniti in dotazione)

Ⓒ TAGISOLERING - med glatte XPS-plader (2cm) som ekstraudstyr (følger ikke med)

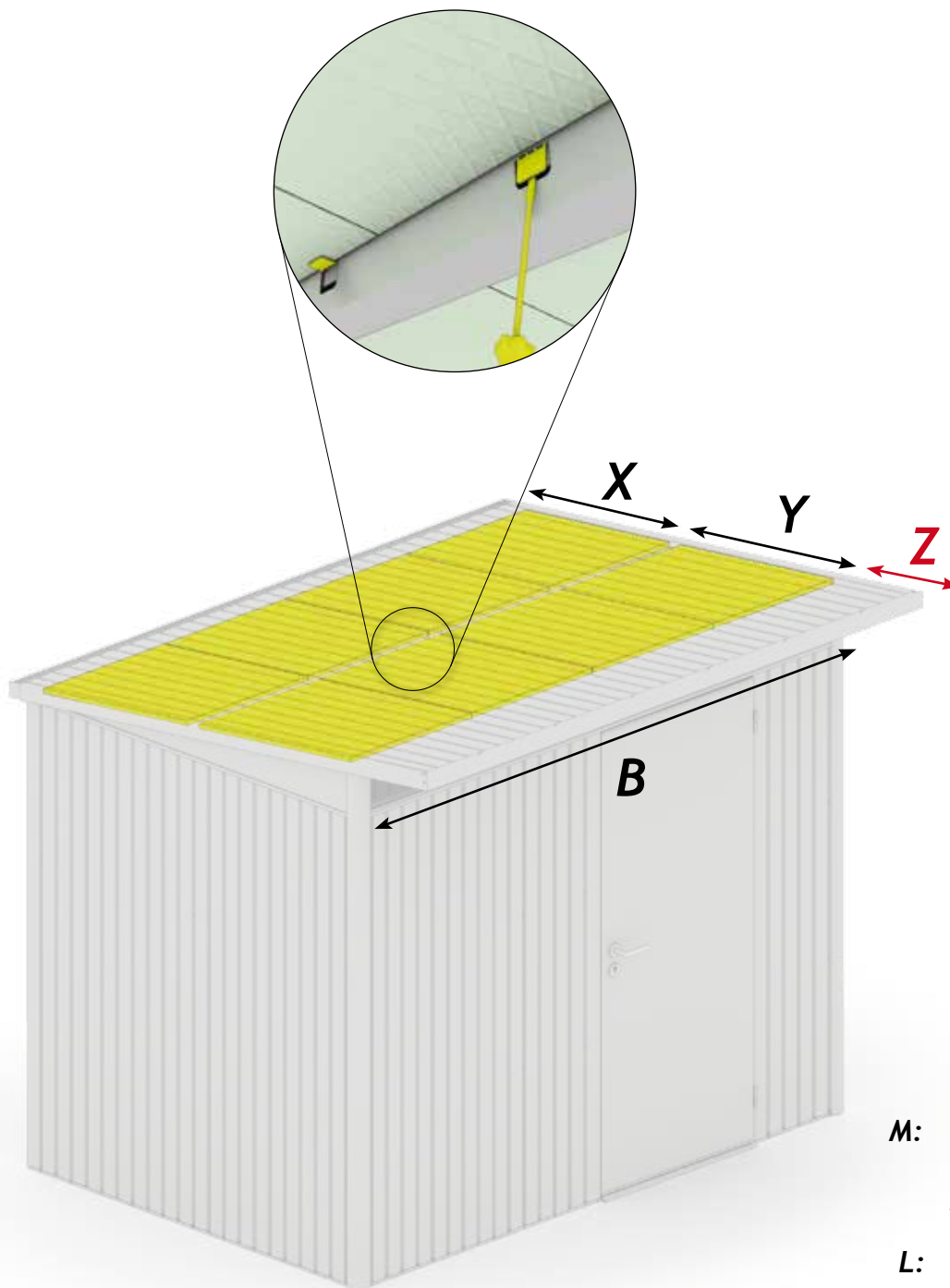

M: X = 760mm
Y = 805mm
B = 1730mm

L: X = 760mm
Y = 805mm
B = 2530mm

XL: X = 760mm
Y = 945mm
Z = 595mm
B = 2530mm



Bodenplatte

Floor Panels - Cadre de sol - Plaque de fond - Bodemplaat - Placa de suelo - Pavimentazione - Bundplader

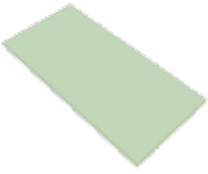
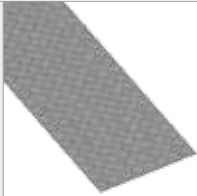
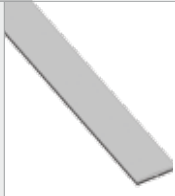
	M: 5x (1250 x 600mm)		M: 1x (1636 x 135mm) 2x (1636 x 746mm)		M: 2x (1635mm)
	L: 6x (1250 x 600mm)		L: 1x (2436 x 135mm) 2x (2436 x 746mm)		L: 2x (2436mm)
	XL: 9x (1250 x 600mm)		XL: 3x (2436 x 746mm) 1x (2436 x 185mm)		XL: 3x (2436mm)

Unterbau für Bodenplatten mit XPS-Platten (2cm od. 3cm)

(nicht im Lieferumfang)

- Ⓒ(GB) Substructure of the floor panels with XPS-boards (2 cm | 3 cm) (not included in the scope of delivery)
- Ⓒ(FR) Les plaques XPS (2 cm | 3 cm) pour les plaques de fond ne sont pas fournies.
- Ⓒ(NL) De XPS- platen die onder de bodemplaat komen, zijn bij de levering niet inbegrepen.
- Ⓒ(ES) Las placas XPS (2cm | 3 cm) sobre las que se coloca la placa de suelo no forman parte del suministro.
- Ⓒ(IT) Placca XPS (2cm | 3 cm) per basamento di una pavimentazione in alluminio non forniti in dotazione.
- Ⓒ(DK) Underlæg for bundplader med XPS-plader (2 cm eller 3 cm)

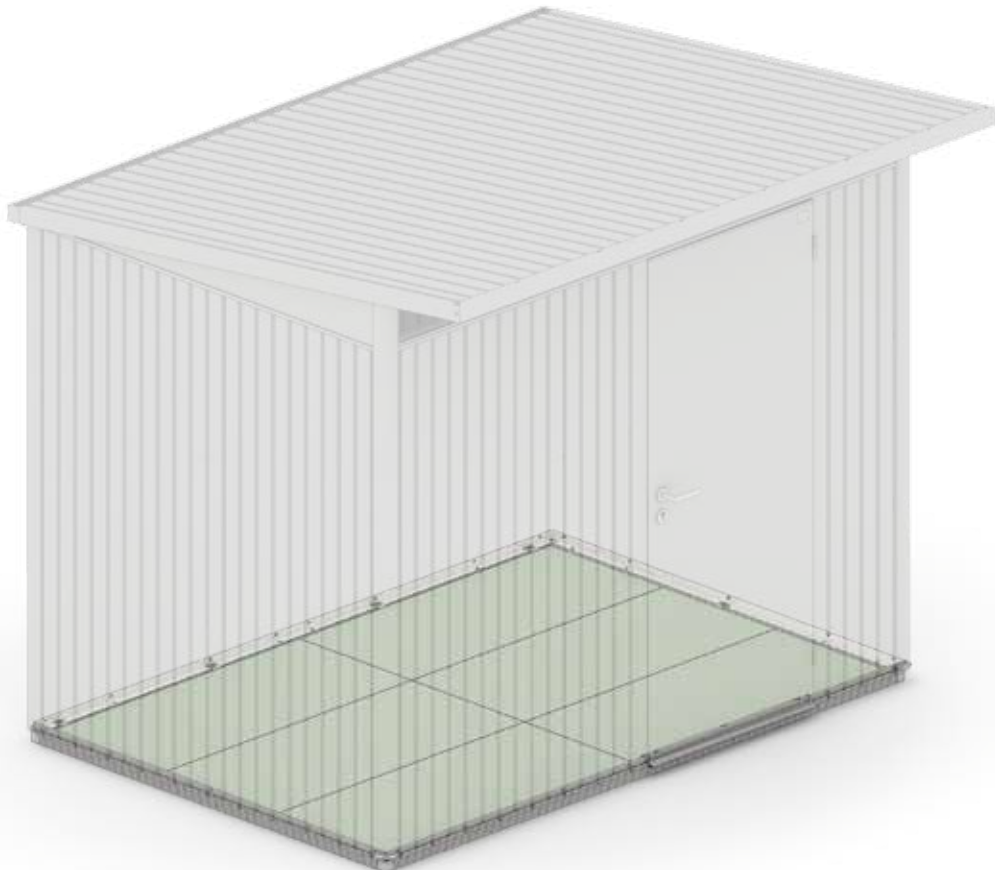

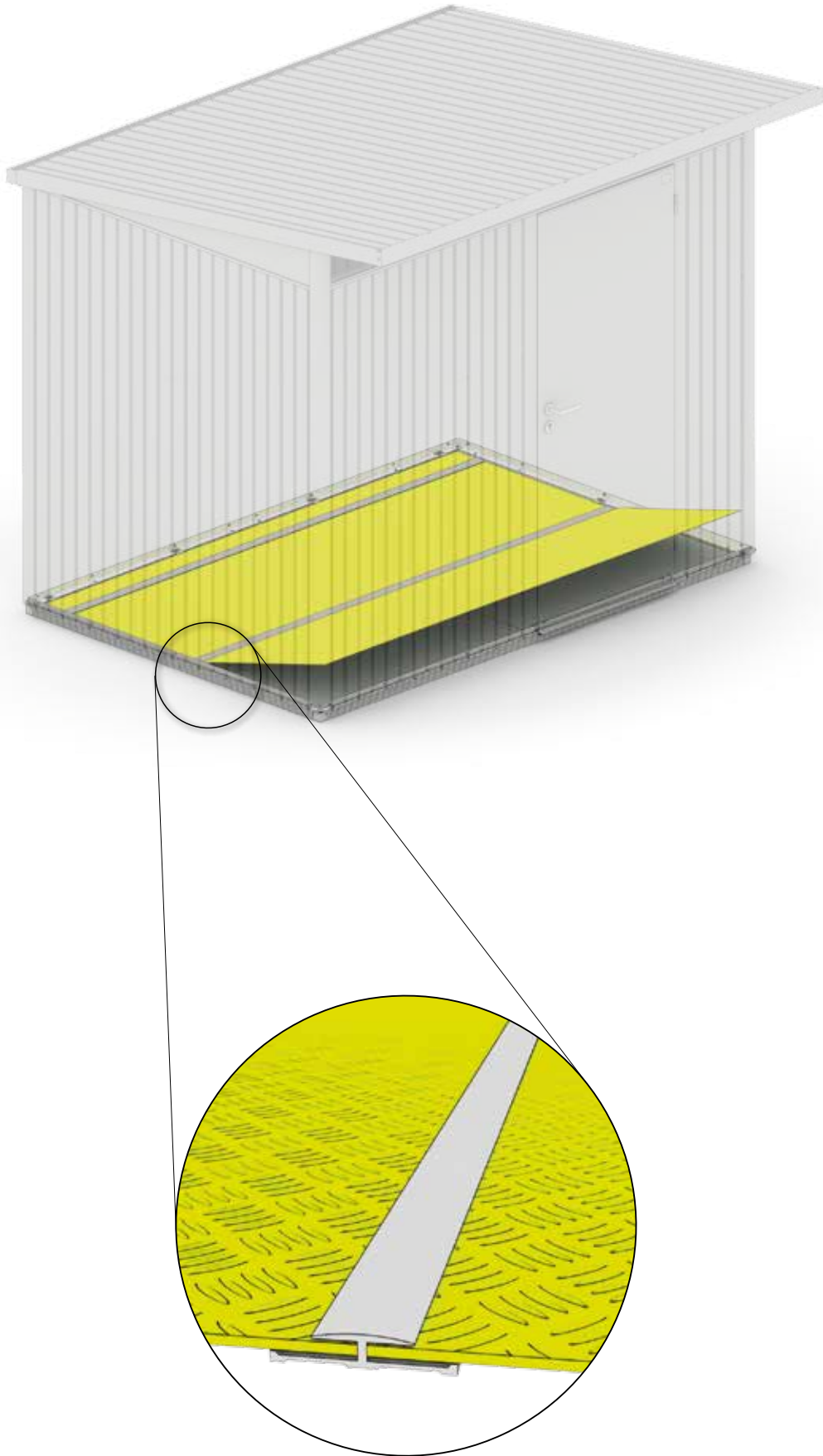

Einreichplan

für die Aufstellung eines
Biohort-Gerätehauses
Modell „AvantGarde“

Approval plan

for the erection of
Biohort garden shed
model "AvantGarde"

Demande

d'autorisation pour la
mise en place d'un abri
de jardin Biohort Modèle
« AvantGarde »

Plan van goedkeuring

voor het bouwen van
het Biohort tuinhuis
model "Avantgarde"

Adresse Aufstellort / Address at site of erection / Adresse du terrain / Platsingsadres

Grundbuch-Einlagezahl
Land register-Site No. / Cadastre
Katastralgemeinde

Grundstücks-Nr.
Property No. / Parcelle n°
Kadastraal nummer

Katastralgemeinde
Council/Borough responsible
Section/Commune / Eigendomsnummer

Bauerber

Building applicant

Demandeur / Opbouwer

Vorname / Christian name / Prénom / Voornaam

Familienname / Surname / Nom / Achternaam

Anschrift / Address / Adresse / Adres

Unterschrift des Bauerbers / Signature of applicant / Signature du demandeur / Handtekening eigenaar

Grundstückseigentümer

Property owner

Propriétaire du terrain

Landeigenaar

Vorname / Christian name / Prénom / Voornaam

Familienname / Surname / Nom / Achternaam

Anschrift / Address / Adresse / Adres

Unterschrift des Grundstückseigentümers / Signature of property owner
Signature du propriétaire / Handtekening eigenaar

Bodenfläche des Biohort-Gerätehauses:

Floorspace of biohort garden shed:
Surface au sol de l'abri de jardin Biohort :
Oppervlakte van het Biohort tuinhuis:

- o Größe M / Size M / Taille M / Grootte M = 3,00 m²
- o Größe L / Size L / Taille L / Grootte L = 4,40 m²
- o Größe XL / Size XL / Taille XL / Grootte XL = 6,45 m²

Gesamte bebaute Fläche

Total built-up area / Surface totale bâtie / Totaal bebouwde oppervlakte

Gartenfläche

Garden area / Surface du jardin / Tuin oppervlakte

Altbau bewilligt

Erection authorised by
Permis de construire du bâtiment existant sur le terrain N°
Opdracht tot opbouw door

vom

Date / En date du / Datum

Verein

Association / Société / Vereniging

Lageplan 1 : 500

Siteplan 1 : 500
Plan de masse 1 : 500
Map 1 : 500

Abmessungen Gerätehaus „AvantGarde®“ M, L und XL in cm

dimensions garden shed “AvantGarde®” M, L and XL in cm

dimensions des abri de jardin « AvantGarde® » M, L et XL en cm

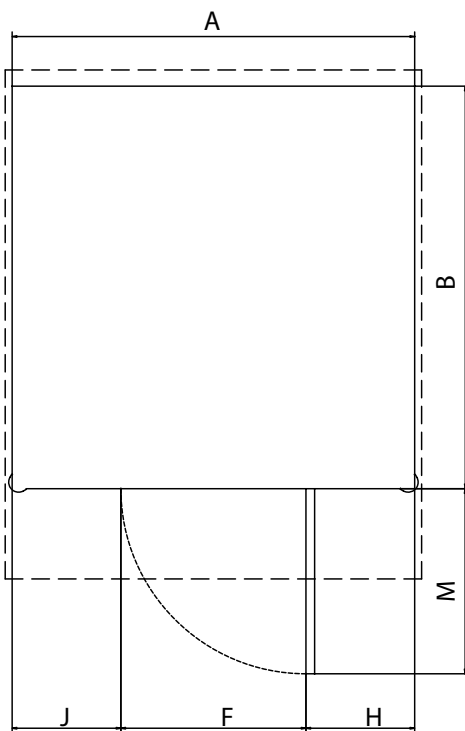
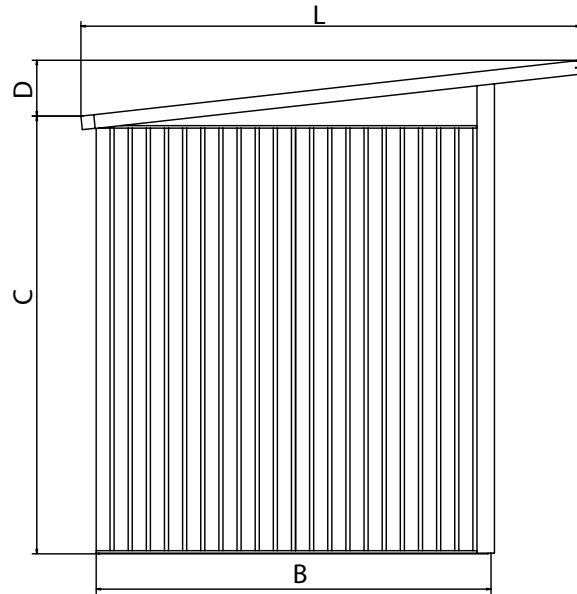
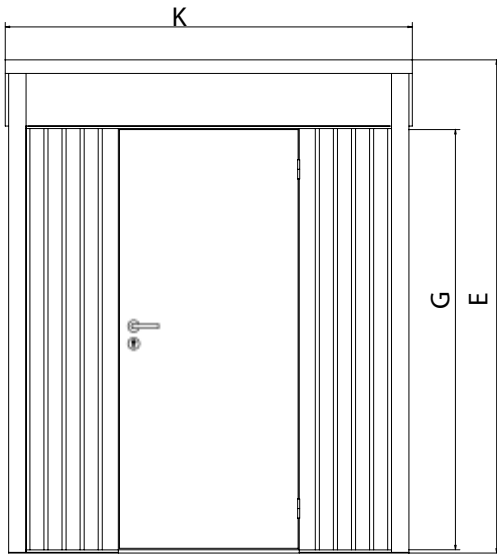

Maßbezeichnungen Description Dimensions référencées sur les dessins Benaming van de maten	Größe M size M taille M grootte M	Größe L size L taille L grootte L	Größe XL size XL taille XL grootte XL	
Gerätehausbreite (ohne Dachvorsprung) Tool Shed width (excl. Roof overhang) Largeur de l'abri de jardin (sans débord de toit) Tuinhuisbreedte (zonder luifel)	A	174	254	254
Gerätehauslänge (ohne Dachvorsprung) Tool Shed length (excl. Roof overhang) Longueur de l'abri de jardin (sans débord de toit) Tuinhuislengte (zonder luifel)	B	174	174	254
Gerätehaushöhe bis Regenrinne Tool Shed height top edge of gutter Hauteur de l'abri de jardin jusqu'à la gouttière Tuinhuishoogte tot bovenkant van het dak	C	193	193	193
Höhe Regenrinne bis Dachoberkante Height from top edge of gutter to roof ridge Hauteur de la gouttière jusqu'à la partie sup. du toit Hoogte regenpijp tot bovenkant van het dak	D	25	25	25
Gerätehausgesamthöhe • Tool Shed complete height Hauteur totale de l'abri de jardin • Totale tuinhuishoogte	E	218	218	218
Durchgangslichte – Breite Door opening – width Ouverture de passage de la porte - largeur Doorgangmaat - lengte	F	76	76	76
Durchgangslichte – Breite (optional 2.Türflügel) Door opening – width (optional 2nd door wing) Ouverture de passage de la porte - largeur (option 2 battants) Doorgangmaat - lengte (met tweede deurvleugel)	---		(156)	(156)
Durchgangslichte – Höhe Door opening – height Ouverture de passage de la porte - hauteur Doorgangmaat - hoogte	G	182	182	182
Seitenbreite rechts • Width of front facade - righthand side Largeur du côté droit • Zijbreedte rechts	H	49	49/129	49/129
Seitenbreite links • Width of front facade - lefthand side Largeur du côté gauche • Zijbreedte links	J	49	129/49	129/49
Dachbreite • Roof width • Largeur du toit • Dakbreedte	K	180	260	260
Dachlänge • Roof length • Longueur du toit • Daklengte	L	220	220	300
Türplatzbedarf beim Öffnen Clearance required for opening doors Encombrement d'ouverture de la porte Ruimte van de deur bij openen	M	80	80	80



HighLine®

Das ultimative Gerätehaus, das hinsichtlich Sicherheit und Funktionalität alle Anforderungen erfüllt.



Panorama®

Dieses Satteldachmodell passt in jedes Gartenpanorama. Stabilität und Design für höchste Ansprüche.



AvantGarde®

Passt bestens zu moderner Architektur und macht lebenslang Freude.



Europa

Alles in bester Ordnung und lebenslange Wartungsfreiheit mit dem Biohort-Klassiker.



Geräteschrank

Wo Raum knapp ist, zeigt er seine Klasse – im Garten, auf der Terrasse, in der Garage.



MiniGarage

Multifunktionales Stauraumwunder ohne Genehmigungspflicht.



WoodStock®

Kaminholzlager und Geräteschrank in einem, auch zum einfachen Wand-Anbau geeignet.



StoreMax®

Funktionelles Design für maximalen Stauraum auf wenig Platz.



HighBoard

Das formvollendete Multitalent zum Aufbewahren. Mit Flügeltüren und Deckelöffnung.



CornerBoard

Bietet wertvollen Platz auf Balkon und Terrasse.



LoungeBox®

Die Design-Box für gehobene Ansprüche - ein Schmuckstück für Terrasse und Garten.



FreizeitBox

Ideal zum Verstauen von Sitzkissen, Sonnenliegen und Spielzeug.



HochBeet

Schönste Aussicht auf beste Ernte.



Pflanzbeet Belvedere®

Der Blickfang für die Terrasse.



Komposter MonAmi®

Vereint Zweckmäßigkeit mit stilvollem Auftreten.



Nebengebäude CasaNova®

Design, das sich Ihren Wünschen anpasst.

Ihr Fachhändler:



Biohort GmbH

Pürnstein 43, 4120 Neufelden, Österreich
Tel.: +43-7282-7788-0, Fax-DW: 190
E-Mail: office@biohort.at, www.biohort.com